

## FITTING INSTRUCTION

Clamp mark in acc. with		Cables joining
ISO	PN	
1	L	Left directional lights
2	+	Rear fog lights
3	31	Ground
4	R	Right directional lights
5	58R	Right side parking lights
6	54	Stoplights
7	58L	Left side parking lights

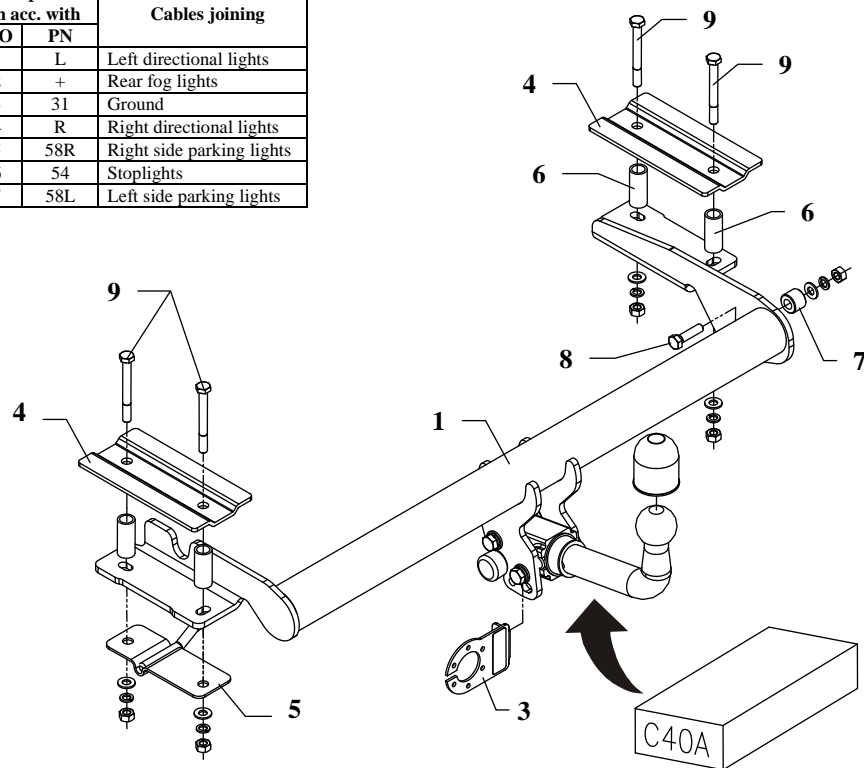

This towbar is designed to assembly in following cars:  
**FORD ORION, 4 doors**, produced since 10.1990 till 09.1994 and  
**FORD ESCORT, 4 doors**, produced since 10.1990 till 12.1995, catalogue no. **C40A** and is prepared to tow trailers max total weight **1200 kg** and max vertical load **50 kg**.

### *From manufacturer*

Thank you for buying our product. Their reliability has been confirmed in many tests. Reliability of towbar depends also on correct assembly and right operation. For this reasons we kindly ask to read carefully this instruction and apply to hints.

*The towbar should be install in points described by a car producer.*

## The instruction of the assembly

1. To install the towbar it is not necessary to take off the bumper.
2. Find original marked places inside the boot on the left and right side, then drill  $\varnothing 24\text{mm}$ .
3. Into so prepared holes put distance sleeves  $L=50\text{mm}$  (pos. 6) and then apply fish-plates (pos. 4) from the accessories.
4. Position the main bar of the towbar (pos. 1) and fix it through the original holes, sleeves and the fish-plates (pos. 4) using bolts  $M10 \times 90\text{mm}$  (pos. 9).
5. Fix through the original hole and fabric towing eye on the right side using  $M10 \times 40\text{mm}$  bolt (pos. 8). Use the sleeve  $\varnothing 25 \times 5\text{mm}$ ,  $L=19\text{mm}$  (pos. 7).
6. Fix body of the automat and place tow-ball according to supplied instruction. Note! Remember to place socket plate (pos. 3) as shown on the drawing 1.
7. Tighten all bolts according to the torque shown in the table.
8. Connect electric wires of 7-poles socket according to the instruction of the car. (Recommend to make at authorized service station).
9. Complete paint layer damaged during installation.

Torque settings for nuts and bolts (8,8):	
<b>M 8</b> - 25 Nm	<b>M 10</b> - 55 Nm
<b>M 12</b> - 85 Nm	<b>M 14</b> - 135 Nm

### NOTE

After install the towbar you should get adequate note in registration book (at authorised service station). The car should be equipped with:

- Indicators
- Tow mirrors

After 1000km check all bolts and nuts. The ball of towbar must be always kept clear and conserve with a grease.

## Towbar accessories:

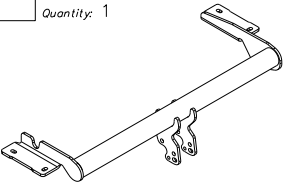
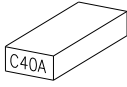
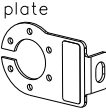
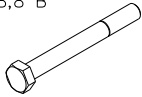
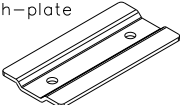
Pos. 1 Name: Main bar Quantity: 1	Pos. 5 Name: Handle Quantity: 1	Pos. 10 Name: Nut 8 B Quantity: 5 Dim.: M10
	Pos. 6 Name: Distance sleeve Quantity: 4 Dim.: Ø21.3x2.6mm, L=50mm	Pos. 11 Name: Plain washer Quantity: 5 Dim.: Ø 10,5 mm
Pos. 2 Name: Tow ball Quantity: 1	Pos. 7 Name: Distance sleeve Quantity: 1 Dim.: Ø25xØ13mm, L=19mm	Pos. 12 Name: Spring washer Quantity: 5 Dim.: Ø 10,2 mm
	Pos. 8 Name: Bolt 8,8 B Quantity: 1 Dim.: M10x40mm	
Pos. 3 Name: Socket plate Quantity: 1	Pos. 9 Name: Bolt 8,8 B Quantity: 4 Dim.: M10x90mm	
		
Pos. 4 Name: Fish-plate Quantity: 2		
		



## PPUH AUTO-HAK S.J.

Produkcja Haków Holowniczych  
Henryk i Zbigniew Nejman  
76-200 SŁUPSK ul. Słoneczna 16K  
tel/fax (059) 8-414-414; 8-414-413  
E-mail: [office@autohak.com.pl](mailto:office@autohak.com.pl)  
[www.autohak.com.pl](http://www.autohak.com.pl)

## Towing hitch (without electrical set)

Class: **A50-X** Cat. no. **C40A**

Designed for:

Manufacturer: **FORD**

Model: **ORION**

Type: **4 doors**

produced since 10.1990 till 09.1994

Model: **ESCORT**

Type: **4 doors**

produced since 10.1990 till 12.1995

Technical data:

**D-value: 6,64 kN**

maximum trailer weight: **1200 kg**

maximum vertical cup load: **50 kg**

Approval number according to Directive 94/20/EC: **e20\*94/20\*0484\*00**

## Foreword

This towbar is designed according to rules of safety traffic regulations. The towing hitch is a safety component and can be install only by qualified personnel. Any alteration or conversion of the towing hitch is prohibited and would lead to cancellation of design certification. Remove insulating compound and underseal from vehicle (if present) in the area of the matting surfaces of the towing hitch.

The vehicle manufacturer's specifications regarding trailer load and max. vertical cup load are decisive for driving, and values for the towing hitch cannot be exceeded.

*D-value formula:*

$$\frac{\text{Max trailer weight [kg]} \times \text{Max vehicle weight [kg]}}{\text{Max trailer weight [kg]} + \text{Max vehicle weight [kg]}} \times \frac{9,81}{1000} = D \text{ [kN]}$$