

FITTING INSTRUCTION

Clamp mark in acc. with		Cables joining
ISO	PN	
1	L	Left directional lights
2	+	Rear fog lights
3	31	Ground
4	R	Right directional lights
5	58R	Right side parking lights
6	54	Stoplights
7	58L	Left side parking lights

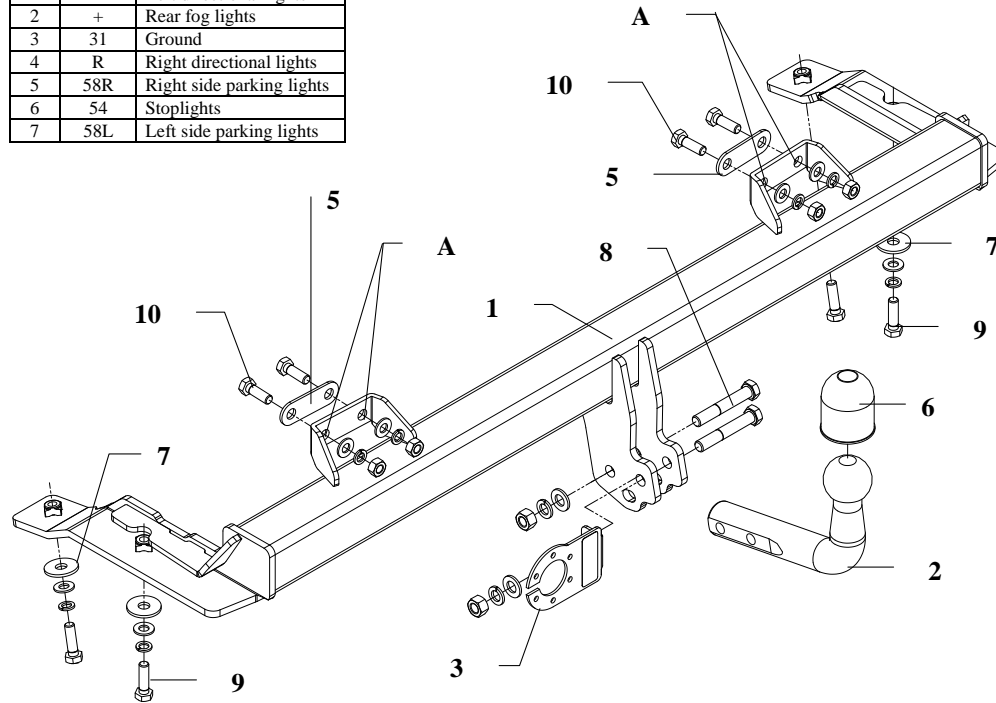

This towing hitch is designed to assembly in following car: **SEAT TOLEDO, 5 doors (1L)**, produced since 05.1991 till 10.1995, catalogue no. **SC04** and is prepared to tow trailers max total weight **1430 kg** and max vertical load **80 kg**.

From manufacturer

Thank you for buying our product. Their reliability has been confirmed in many tests. Reliability of towing hitch depends also on correct assembly and right operation. For this reasons we kindly ask to read carefully this instruction and apply to hints.

The towing hitch should be install in points described by a car producer.

The instruction of the assembly

1. Disassemble the bumper.
2. Disassemble bumper handles (not used any more).
3. In places of unscrewed original handles fix handles from towing hitch accessories (see table, pos. 4).
4. In bumper, in factory marked place (bottom), cut out its fragment 90x130mm.
5. Put the main bar of the towing hitch into chassis members, next through original holes underneath the car fix it using bolts M10x35mm (pos. 9), use plain washer $\varnothing 35 \times 12 \times 4$ mm (pos. 7).
6. Through holes (pos. A) drill holes using bit $\varnothing 10,5$ mm and next fix using bolts M10x30mm (pos. 10), use plain washers with two holes (pos. 5).
7. Reinstall the bumper.
8. Tighten all bolts according to the torque shown in the table.
9. Fix tow-ball (pos. 2) and socket plate (pos. 3) using bolts M12x75mm (pos. 8) from accessories.
10. Connect electric wires of 7-poles socket according to the instruction of the car. (Recommend to make at authorized service station)
11. Complete paint layer damaged during installation.

Torque settings for nuts and bolts (8,8):

M6 - 11 Nm	M 8 - 25 Nm	M 10 - 50 Nm
M 12 - 87 Nm	M 14 - 138 Nm	M16 - 210 Nm











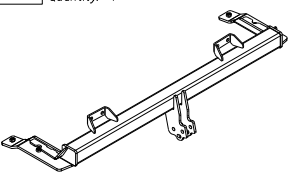
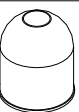

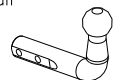
NOTE

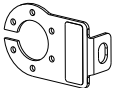
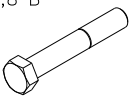
After installation of a towing hitch you should get adequate note in registration book (at authorised service station). The car should be equipped with:

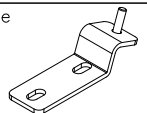
- Indicators
- Tow mirrors

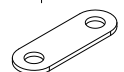
After 1000km of exploitation check all bolts and nuts. The ball of towing hitch must be always kept clear and conserve with a grease.

Towing hitch accessories:

Pos. 1	Name: Main bar Quantity: 1	Pos. 6	Name: Ball cover Quantity: 1	Pos. 12	Name: Nut 8 B Quantity: 4 Dim. : M10
					
Pos. 2	Name: Tow ball Quantity: 1	Pos. 7	Name: Washer Quantity: 4 Dim. : Ø35xØ12x4 mm	Pos. 13	Name: Plain washer Quantity: 2 Dim. : Ø13 mm
					
Pos. 3	Name: Socket plate Quantity: 1	Pos. 8	Name: Bolt 8,8 B Quantity: 2 Dim. : M12x75mm	Pos. 14	Name: Plain washer Quantity: 8 Dim. : Ø10,5 mm
					
Pos. 4	Name: Handle Quantity: 2	Pos. 9	Name: Bolt 8,8 B Quantity: 4 Dim. : M10x35 mm	Pos. 15	Name: Spring washer Quantity: 2 Dim. : Ø12,2 mm
					
Pos. 5	Name: Plain fish-plate Quantity: 2	Pos. 10	Name: Bolt 8,8 B Quantity: 4 Dim. : M10x30 mm	Pos. 16	Name: Spring washer Quantity: 8 Dim. : Ø10,2 mm
					
Pos. 11	Name: Nut 8 B Quantity: 2 Dim. : M12				
					



PPUH AUTO-HAK Sp.J.

Produkcja Zaczepów Kulowych
Henryk i Zbigniew Nejman
76-200 SŁUPSK ul. Słoneczna 16K
tel/fax (059) 8-414-414; 8-414-413
E-mail: office@autohak.com.pl
www.autohak.com.pl

Towing hitch (without electrical set)

Class: **A50-X** Cat. no. **SC04**

Designed for:

Manufacturer: **SEAT**

Model: **TOLEDO**

Type: **5 doors (1L)**

produced since 05.1991 till 10.1995

Technical data:

D-value: 7,39 kN

maximum trailer weight: **1430 kg**

maximum vertical cup load: **80 kg**

Approval number acc. to regulations EKG/ONZ 55.01: E20-55R-01 1341

Foreword

This towing hitch is designed according to rules of safety traffic regulations. The towing hitch is a safety component and can be installed only by qualified personnel. Any alteration or conversion of the towing hitch is prohibited and would lead to cancellation of design certification. Remove insulating compound and underseal from vehicle (if present) in the area of the mating surfaces of the towing hitch.

The vehicle manufacturer's specifications regarding trailer mass and max. vertical cup mass are decisive for driving whereat values for the towing hitch cannot be exceeded.

D-value formula:

$$\frac{\text{Max trailer weight [kg]} \times \text{Max vehicle weight [kg]}}{\text{Max trailer weight [kg]} + \text{Max vehicle weight [kg]}} \times \frac{9,81}{1000} = D \text{ [kN]}$$