

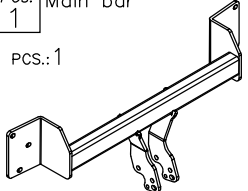

Towing hitch accessories:

Pos. 1 Main bar PCS.: 1	Pos. 6 Fish-plate left PCS.: 1	Pos. 12 Bolt 8.8 B M10x35 PCS.: 6
	Pos. 7 Fish-plate right PCS.: 1	Pos. 13 Washer ø30xø10,5x2,5mm PCS.: 6
Pos. 2 Tow ball (mounting set) PCS.: 1	Pos. 8 Distance sleeve I ø17.2x2.35mm L=16mm PCS: 2	Pos. 14 Washer ø10,5mm PCS.: 6
	Pos. 9 Distance sleeve II ø17.2x2.35mm L=12mm PCS: 2	Pos. 15 Spring washer ø10,2mm PCS.: 12
Pos. 3 Socket plate PCS.: 1	Pos. 10 Distance sleeve III ø17.2x2.35mm L=10mm PCS: 2	Pos. 16 Nut 8 B M10 PCS.: 12
	Pos. 4 Left bracket PCS.: 1	Pos. 11 Bolt 8.8 B M10x50mm PCS.: 6
Pos. 5 Right bracket PCS.: 1		

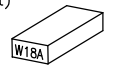
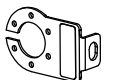

PPUH AUTO-HAK S.J.

Produkcja Zaczepów Kulowych
Henryk & Zbigniew Nejman
76-200 SŁUPSK ul. Słoneczna 16K
tel/fax (059) 8-414-414; 8-414-413
E-mail: office@autohak.com.pl
www. autohak.com.pl

Towing hitch (without electrical set)

Class: **A50-X** Cat. no. **W18A**

Designed for:

Manufacturer: **SUZUKI**

Model: **LIANA**

Type: **5 doors, ESTATE, 4WD**

produced since 05.2001 till 12.2007

Technical data:

D-value: 6,9 kN

maximum trailer weight: **1200 kg**

maximum vertical cup load: **60 kg**

Approval number according to Directive 94/20/EC: e20*94/20*1143*00

Foreword

This towing hitch is designed according to rules of safety traffic regulations. The towing hitch is a safety component and can be installed only by qualified personnel. Any alteration or conversion of the towing hitch is prohibited and would lead to cancellation of design certification. Remove insulating compound and underseal from vehicle (if present) in the area of the mating surfaces of the towing hitch.

The vehicle manufacturer's specifications regarding trailer mass and max. vertical cup mass are decisive for driving whereat values for the towing hitch cannot be exceeded.

D-value formula:

$$\frac{\text{Max trailer weight [kg]} \times \text{Max vehicle weight [kg]}}{\text{Max trailer weight [kg]} + \text{Max vehicle weight [kg]}} \times \frac{9,81}{1000} = D \text{ [kN]}$$

FITTING INSTRUCTION

Clamp mark in acc. with		Cables joining
ISO	PN	
1	L	Left directional lights
2	+	Rear fog lights
3	31	Ground
4	R	Right directional lights
5	58R	Right side parking lights
6	54	Stoplights
7	58L	Left side parking lights

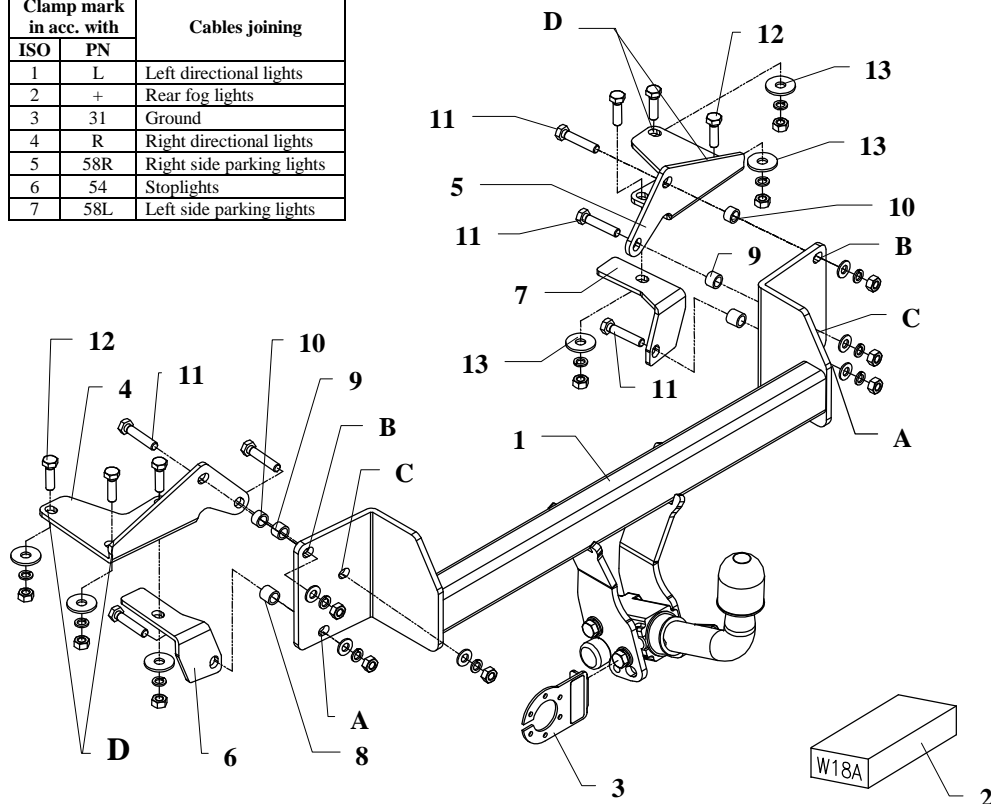

This towing hitch is designed to assembly in following car: **SUZUKI LIANA, 5 doors, ESTATE, 4WD**, produced since 05.2001 till 12.2007, catalogue number **W18A** and is prepared to tow trailers max total weight **1200 kg** and max vertical load **60 kg**.

From manufacturer

Thank you for buying our product. Their reliability has been confirmed in many tests. Reliability of towbar depends also on correct assembly and right operation. For this reasons we kindly ask to read carefully this instruction and apply to hints.

The towbar should be install in points described by a car producer.

The instruction of the assembly

- Disassemble the bumper and brackets.
- Get out the spare wheel.
- From the boot take out the carpet and cover panels (side and rear).
- To rear part of the car put the main bar of the towing hitch (pos. 1) – holes pos. A agree with original holes:
 - mark points through holes B and C (put away the bar)
 - in marked holes drill holes using bit $\varnothing 10,5$ mm
- Put the main bar (pos. 1) again and:
 - through all holes put bolts M10x50mm (pos. 11) and fix with elements (pos. 4 and 5) – put them from the inside.

Attention!!! Before fix, put distance sleeves (pos. 8, 9 and 10)! – see the drawing)
- Through holes pos. D in elements (pos. 4 and 5) drill holes using bit $\varnothing 10,5$ mm and next fix with elements (pos. 6 and 7) – put them underneath the car - see the drawing.
- Reassemble the bumper after cut out (in axis) its fragment length 85 mm, width 55 mm.
- Fix body of the automat and place tow-ball according to supplied instruction. Note! Remember to place socket plate (pos. 3) as shown on the drawing 1.
- Tighten all bolts according to the torque shown in the table.
- Mount side panels (cut out fragments for bolt heads).
- Connect electric wires according to the instruction of the car. (Recommend to make at authorized service station)
- Complete paint layer damaged during installation.

Torque settings for nuts and bolts (8,8):

M6 - 11 Nm	M 8 - 25 Nm	M 10 - 50 Nm
M 12 - 87 Nm	M 14 - 138 Nm	M16 - 210 Nm

NOTE

After install the towbar you should get adequate registration in registration book (at authorised service station).The car should be equipment with:

- Indicators
- Tow mirrors

After 1000km of exploitation check all bolts and nuts. The ball of towbar must be always kept clear and conserve with a grease.