

FITTING INSTRUCTION

Clamp mark in acc. with		Cables joining
ISO	PN	
1	L	Left directional lights
2	+	Rear fog lights
3	31	Ground
4	R	Right directional lights
5	58R	Right side parking lights
6	54	Stoplights
7	58L	Left side parking lights

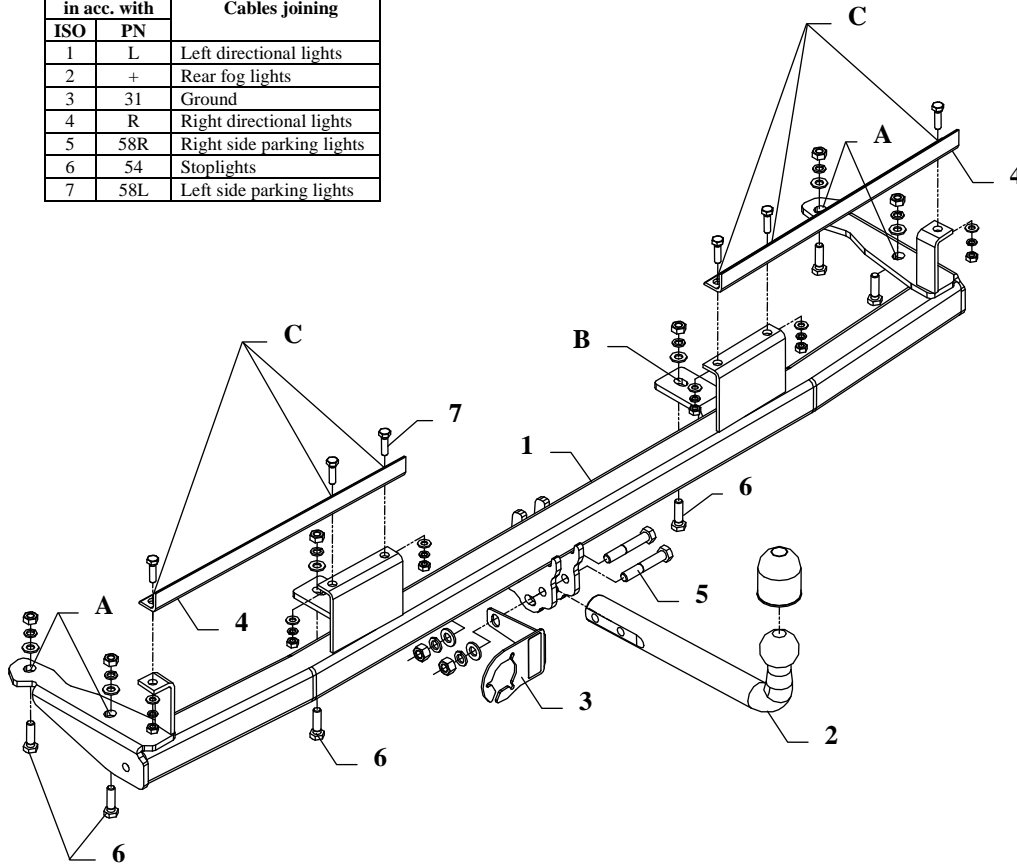

This towbar is designed to assembly in following cars:
BMW 7 series, E32, 4 doors, produced since 08.1986 till 05.1994, catalogue no. **B05** and is prepared to tow trailers max total weight **1600 kg** and max vertical load **50 kg**.

From manufacturer

Thank you for buying our product. Their reliability has been confirmed in many tests. Reliability of towbar depends also on correct assembly and right operation. For this reasons we kindly ask to read carefully this instruction and apply to hints.

The towbar should be install in points described by a car producer.

The instruction of the assembly

1. For install the towbar, first disassemble the bumper and the rear casing from the inside of the carrier.
2. Unscrew the grips used to mount the bumper.
3. Apply the main bar of the towbar (pos. 1) to the chassis of vehicle and through the holes (pos. A and B) fix loosely with the M10x35mm bolts (pos. 6). Use the flat and spring washers.
4. Twist the grips of the bumper. (*Attention! In some versions, the grips can clash with the construction of towbar. Then, if it is necessary rasp the grips.*)
5. Tighten all bolts according to the torque shown in the table.
6. Across the holes (pos. C) drill holes $\varnothing 9\text{mm}$, and then twist with the angle bars (pos. 4) using bolts M8x30mm (pos. 7).
7. Cut out a hole $\varnothing 60\text{mm}$ in the bumper, as showed on the drawing.

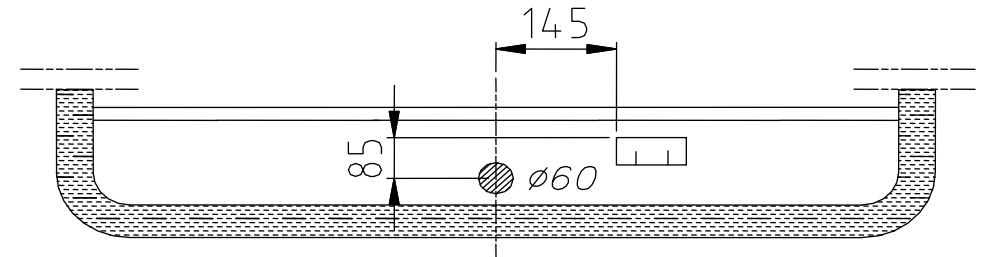

8. Mount the bumper and the rear casing.
9. To the installed towbar mount the towball (pos. 2) and the socket plate (pos. 3) with bolts M12x75mm (pos. 5) from accessories.
10. Connect electric wires of 7-poles socket according to the instruction of the car. (Recommend to make at authorized service station).
11. Complete paint layer damaged during installation.

Torque settings for nuts and bolts (8,8):

M6 - 11 Nm	M 8 - 25 Nm	M 10 - 50 Nm
M 12 - 87 Nm	M 14 - 138 Nm	M16 - 210 Nm











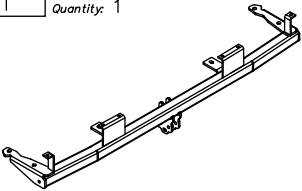

NOTE

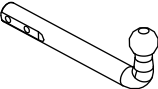
After install the towbar you should get adequate note in registration book (at authorised service station).The car should be equipped with:

- Indicators
- Tow mirrors

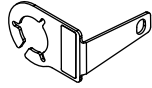
After 1000km of exploitation check all bolts and nuts. The ball of towbar must be always kept clear and conserve with a grease.

Towbar accessories:

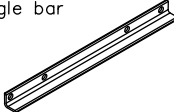
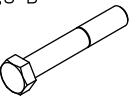
Pos. 1	Name: Main bar Quantity: 1 	Pos. 6	Name: Bolt 8,8 B Quantity: 6 Dim.: M10x35mm 	Pos. 12	Name: Plain washer Quantity: 6 Dim.: Ø 10,5 mm 
		Pos. 7	Name: Bolt 8,8 B Quantity: 6 Dim.: M8x30mm 	Pos. 13	Name: Plain washer Quantity: 6 Dim.: Ø 8,5 mm 
Pos. 2	Name: Tow ball Quantity: 1 	Pos. 8	Name: Nut 8 B Quantity: 2 Dim.: M12 	Pos. 14	Name: Spring washer Quantity: 2 Dim.: Ø 12,2 mm 
		Pos. 9	Name: Nut 8 B Quantity: 6 Dim.: M10 	Pos. 15	Name: Spring washer Quantity: 6 Dim.: Ø 10,2 mm 
Pos. 3	Name: Socket plate Quantity: 1 	Pos. 10	Name: Nut 8 B Quantity: 2 Dim.: M8 	Pos. 16	Name: Spring washer Quantity: 6 Dim.: Ø 8,2 mm 
		Pos. 11	Name: Plain washer Quantity: 2 Dim.: Ø 13 mm 	Pos. 17	Name: Ball cover Quantity: 1 
Pos. 4	Name: Angle bar Quantity: 2 Dim.: 30x30x4, L=430mm 	Pos. 5	Name: Bolt 8,8 B Quantity: 2 Dim.: M12x75mm 		



PPUH AUTO-HAK Sp.J.

Produkcja Zaczepów Kulowych
Henryk i Zbigniew Nejman
76-200 SŁUPSK ul. Słoneczna 16K
tel/fax (059) 84-14-414; 84-14-413
e-mail: office@autohak.com.pl
www.autohak.com.pl

Towing hitch (without electrical set)

Class: **A50-X** Cat. no. **B05**

Designed for:

Manufacturer: **BMW**

Model: **SERIES 7 (E32)**

Type: **4 doors**

produced since 08.1986 till 05.1994

Technical data:

D-value: 9,35 kN

maximum trailer weight: **1600 kg**

maximum vertical cup load: **50 kg**

Approval number acc. to regulations EKG/ONZ 55.01: **E20-55R-01 1049**

Foreword

This towbar is designed according to rules of safety traffic regulations. The towing hitch is a safety component and can be install only by qualified personnel. Any alteration or conversion of the towing hitch is prohibited and would lead to cancellation of design certification. Remove insulating compound and underseal from vehicle (if present) in the area of the matting surfaces of the towing hitch.

The vehicle manufacturer's specifications regarding trailer load and max. vertical cup load are decisive for driving, and values for the towing hitch cannot be exceeded.

D-value formula:

$$\frac{\text{Max trailer weight [kg]} \times \text{Max vehicle weight [kg]}}{\text{Max trailer weight [kg]} + \text{Max vehicle weight [kg]}} \times \frac{9,81}{1000} = D \text{ [kN]}$$