

FITTING INSTRUCTION

Clamp mark in acc. with		Cables joining
ISO	PN	
1	L	Left directional lights
2	+	Rear fog lights
3	31	Ground
4	R	Right directional lights
5	58R	Right side parking lights
6	54	Stoplights
7	58L	Left side parking lights

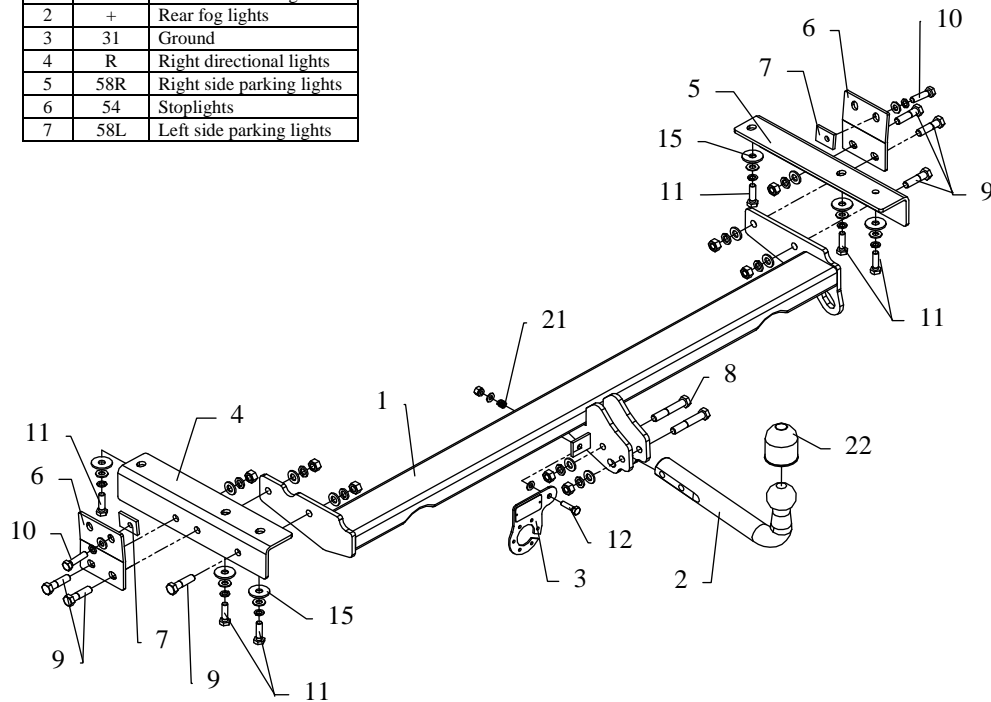

This towbar is designed to assembly in following cars: **TOYOTA LEXUS RX300, (XU1), 1 exhaust pipe**, produced since 07.2000 till 04.2003, catalogue number **O62** and is prepared to tow trailers max total weight **2200 kg** and max vertical load **75 kg**.

From manufacturer

Thank you for buying our product. Their reliability has been confirmed in many tests. Reliability of towbar depends also on correct assembly and correct exploitation. For this reasons we kindly ask to read carefully this instruction and apply to hints.

The towbar should be install in points described by a car producer.

The instruction of the assembly

1. Disassemble a original towing eye (not used any more).
2. Remove plugs from threaded holes in chassis members.
3. Underneath the bumper cut fragment according to figure below.

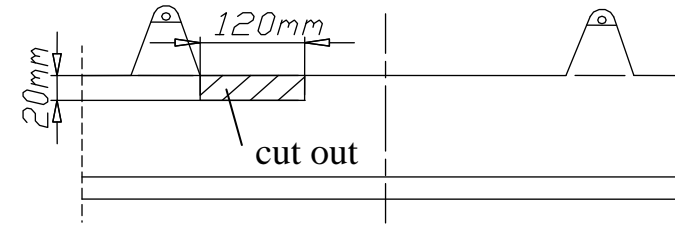

4. To chassis members fix loosely elements pos. 4 and 5 using bolts M10x1,25x35mm (pos. 11) and elements (pos. 6 and 7) using bolts M10x1,25x40mm (pos. 10), see figure.
5. Between installed elements 4 and 5 put main bar of the towbar (pos. 1) and fix it using bolts M12x45mm (pos. 9)
6. Fix tow ball (pos. 2) and using bolts M12x70mm (pos. 9) from accessories.
7. Fix the socket plate (pos. 3) as shown on the drawing.
8. Connect electric wires of 7-poles socket according to the instruction of the car. (Recommend to make at authorized service station).
9. Complete the paint coating damaged during installation.

Torque settings for nuts and bolts (8,8):

M6 - 11 Nm	M8 - 25 Nm	M10 - 50 Nm
M12 - 87 Nm	M14 - 138 Nm	M16 - 210 Nm



NOTE

After install the towbar you should get adequate note in registration book (at authorised service station).The car should be equipped with:

- Indicators
- Tow mirrors

After 1000km of exploitation check all bolts and nuts. The ball of towbar must be always kept clear and conserve with a grease.

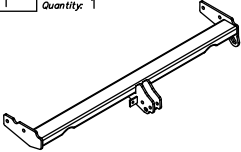
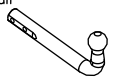
Towbar accessories:

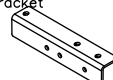
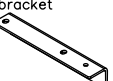
Pos. 1 Name: Main bar Quantity: 1	Pos. 6 Name: Flat bar Quantity: 2	Pos. 12 Name: Bolt 8,8 B Quantity: 1 Dim.: M8x30mm	Pos. 18 Name: Plain washer Quantity: 2 Dim.: \varnothing 8,5 mm
	Pos. 7 Name: Rectangular washer Quantity: 2	Pos. 13 Name: Nut 8 B Quantity: 8 Dim.: M12	Pos. 19 Name: Spring washer Quantity: 8 Dim.: \varnothing 12,2 mm
Pos. 2 Name: Tow ball Quantity: 1	Pos. 8 Name: Bolt 8,8 B Quantity: 2 Dim.: M12x70mm	Pos. 14 Name: Nut 8 B Quantity: 1 Dim.: M8	Pos. 20 Name: Spring washer Quantity: 8 Dim.: \varnothing 10,2 mm
	Pos. 9 Name: Bolt 8,8 B Quantity: 6 Dim.: M12x45mm	Pos. 15 Name: Washer Quantity: 6 Dim.: \varnothing 35x \varnothing 12x3mm	Pos. 21 Name: Spring Quantity: 1
Pos. 3 Name: Socket plate Quantity: 1		Pos. 10 Name: Bolt 8,8 B Quantity: 2 Dim.: M10x40mm	Pos. 16 Name: Plain washer Quantity: 8 Dim.: \varnothing 13 mm
Pos. 4 Name: Left bracket Quantity: 1		Pos. 11 Name: Bolt 8,8 B Quantity: 6 Dim.: M10x35mm	Pos. 17 Name: Plain washer Quantity: 8 Dim.: \varnothing 10,5 mm
Pos. 5 Name: Right bracket Quantity: 1			



PPUH AUTO-HAK Sp.J.

Produkcja Zaczepów Kulowych
Henryk i Zbigniew Nejman
76-200 SŁUPSK ul. Słoneczna 16K
tel/fax (059) 8-414-414; 8-414-413
E-mail: office@autohak.com.pl
www. autohak.com.pl

Towing hitch (without electrical set)

Class: **A50-X** Cat. no. **O62**

Designed for:

Manufacturer: **TOYOTA**

Model: **LEXUS**

Type: **RX300, (XU1), 1 exhaust pipe**

produced since 07.2000 till 04.2003

Technical data:

D-value: 11,0 kN

maximum trailer weight: **2200 kg**

maximum vertical cup load: **75 kg**

Approval number according to Directive 94/20/EC: **e20*94/20*0026*00**

Foreword

This towbar is designed according to rules of safety traffic regulations. The towing hitch is a safety component and can be install only by qualified personnel. Any alteration or conversion of the towing hitch is prohibited and would lead to cancellation of design certification. Remove insulating compound and underseal from vehicle (if present) in the area of the matting surfaces of the towing hitch.

The vehicle manufacturer's specifications regarding trailer load and max. vertical cup load are decisive for driving, and values for the towing hitch cannot be exceeded.

D-value formula:

$$\frac{\text{Max trailer weight [kg]} \times \text{Max vehicle weight [kg]}}{\text{Max trailer weight [kg]} + \text{Max vehicle weight [kg]}} \times \frac{9,81}{1000} = D \text{ [kN]}$$