

FITTING INSTRUCTION

Clamp mark in acc. with		Cables joining
ISO	PN	
1	L	Left directional lights
2	+	Rear fog lights
3	31	Ground
4	R	Right directional lights
5	58R	Right side parking lights
6	54	Stoplights
7	58L	Left side parking lights

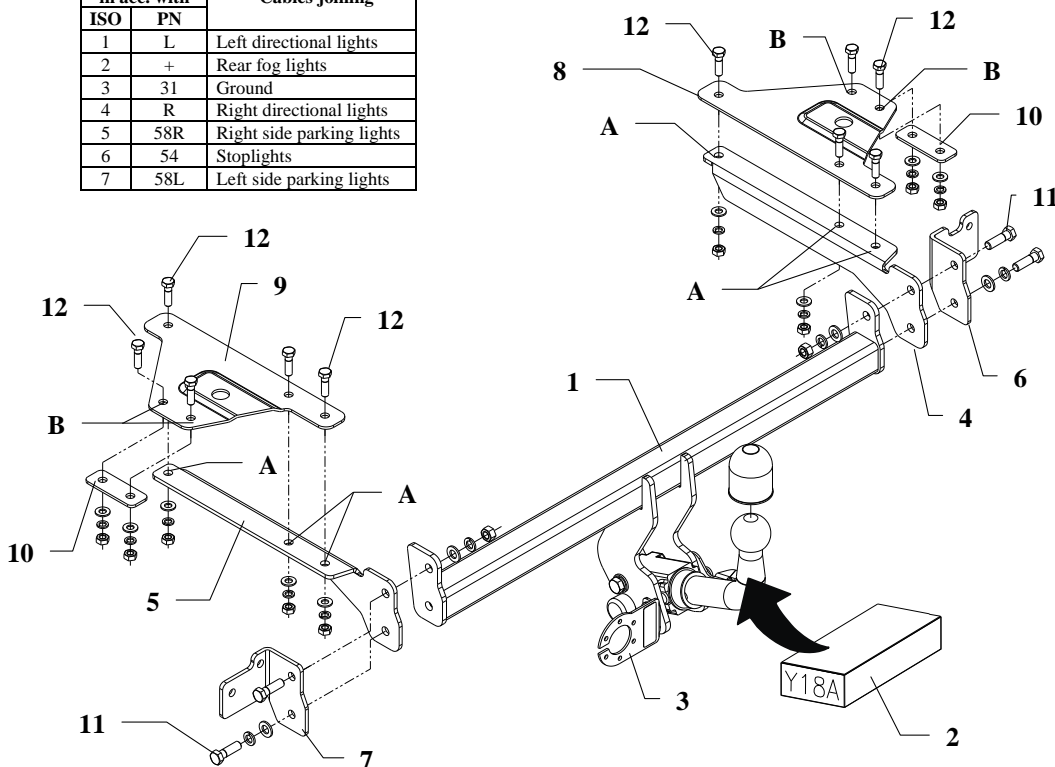

This towbar is designed to assembly in following cars:

HONDA CIVIC 3 doors, produced since 10.2001 till 04.2007, catalogue no. **Y18A** and is prepared to tow trailers max total weight up to **1200 kg** and max vertical mass **50 kg**.

From manufacturer

Thank you for buying our product. Their reliability has been confirmed in many tests. Reliability of towbar depends also on correct assembly and right operation. For this reasons we kindly ask to read carefully this instruction and apply to hints.

The towbar should be install in points described by a car producer.

The instruction of the assembly

1. Disassemble rear bumper, muffler and metal reinforcement (not used any more), inside the trunk disassemble side and rear cover panels.
2. To holes in rear slice put left handle (pos. 7) on the left side and right (pos. 6) on the right side and fix it by bolts M8 which left after disassembled metal reinforcement, fix loosely.
4. To assembled elements fix side brackets pos. 4 and 5 and main bar of the towbar pos. 1 using bolts M12x40mm (pos. 11) – see drawing.
5. Through holes pos. A in brackets pos. 4 and 5 drill straight through holes using bit $\varnothing 11\text{mm}$.
6. Inside trunk put fish-plates (pos. 8 and 9) in this way, so holes in fish-plates agree with drilled holes and fix loosely using bolts M10x35mm (pos. 12).
7. Through holes (pos. B) in fish-plates drill holes straight through using bit $\varnothing 11\text{mm}$ and next fix together with plate pos. 10 using bolts M10x35mm (pos. 12).
8. Reassemble bumper and muffler.
9. Fix body of the automat and place tow-ball according to supplied instruction. Note! Remember to place socket plate (pos. 3) as shown on the drawing 1.
10. Screw tight all bolts according to the torque shown in the table.
11. Connect electric wires of 7-poles socket according to the instruction of the car. (Recommend to make at authorized service station)
12. Complete paint layer damaged during installation.

Torque settings for nuts and bolts (8,8):

M6 - 11 Nm	M8 - 25 Nm	M10 - 50 Nm
M12 - 87 Nm	M14 - 138 Nm	M16 - 210 Nm

NOTE

After install the towbar you should get adequate note in registration book (at authorised service station).The car should be equipped with:

- Indicators
- Tow mirrors

After 1000km of exploitation check all bolts and nuts. The ball of towbar must be always kept clear and conserve with a grease.

Towbar accessories:

Poz. 1 Main bar PCS: 1	Poz. 5 Left bracket PCS: 1	Poz. 10 Plate PCS: 2	Poz. 15 Spring washer Ø12,2mm PCS: 4
	Poz. 6 Right handle PCS: 1	Poz. 11 Bolt 8,8 B M12x40mm PCS: 4	Poz. 16 Spring washer Ø10,2mm PCS: 10
Poz. 2 Tow-ball PCS: 1	Poz. 7 Left handle PCS: 1	Poz. 12 Bolt 8,8 B M10x35mm PCS: 10	Poz. 17 Nut 8 B M12 PCS: 4
Poz. 3 Socket plate PCS: 1	Poz. 8 Right fish-plate PCS: 1	Poz. 13 Plain washer Ø13mm PCS: 4	Poz. 18 Nut 8 B M10 PCS: 10
Poz. 4 Right bracket PCS: 1	Poz. 9 Left fish-plate PCS: 1	Poz. 14 Plain washer Ø10,5mm PCS: 10	



PPUH AUTO-HAK Sp.J.

Produkcja Zaczepów Kulowych
Henryk i Zbigniew Nejman
76-200 SŁUPSK ul. Słoneczna 16K
tel/fax (059) 8-414-414; 8-414-413
E-mail: office@autohak.com.pl
www.autohak.com.pl

Towing hitch (without electrical set)

Class: **A50-X** Cat. no. **Y18A**

Designed for:

Manufacturer: **HONDA**

Model: **CIVIC**

Type: **3 doors**

produced since 10.2001 till 04.2007

Technical data:

D-value: 6,83 kN

maximum trailer weight: **1200 kg**

maximum vertical cup mass: **50 kg**

Approval number according to Directive 94/20/EC : e20*94/20*0502*00

Foreword

This towbar is designed according to rules of safety traffic regulations. The towing hitch is a safety component and must be installed only by qualified personnel. Any alteration or conversion to the towing hitch is prohibited and would lead to cancellation of design certification. Remove insulating compound and underseal from vehicle (if present) in the area of the matting surfaces of the towing hitch.

The vehicle manufacturer's specifications regarding trailer load and max. vertical cup load are decisive for driving, and values for the towing hitch cannot be exceeded.

D-value formula:

$$\frac{\text{Max trailer weight [kg]} \times \text{Max vehicle weight [kg]}}{\text{Max trailer weight [kg]} + \text{Max vehicle weight [kg]}} \times \frac{9,81}{1000} = D \text{ [kN]}$$