

## FITTING INSTRUCTION

Clamp mark in acc. with		Cables joining
ISO	PN	
1	L	Left directional lights
2	+	Rear fog lights
3	31	Ground
4	R	Right directional lights
5	58R	Right side parking lights
6	54	Stoplights
7	58L	Left side parking lights

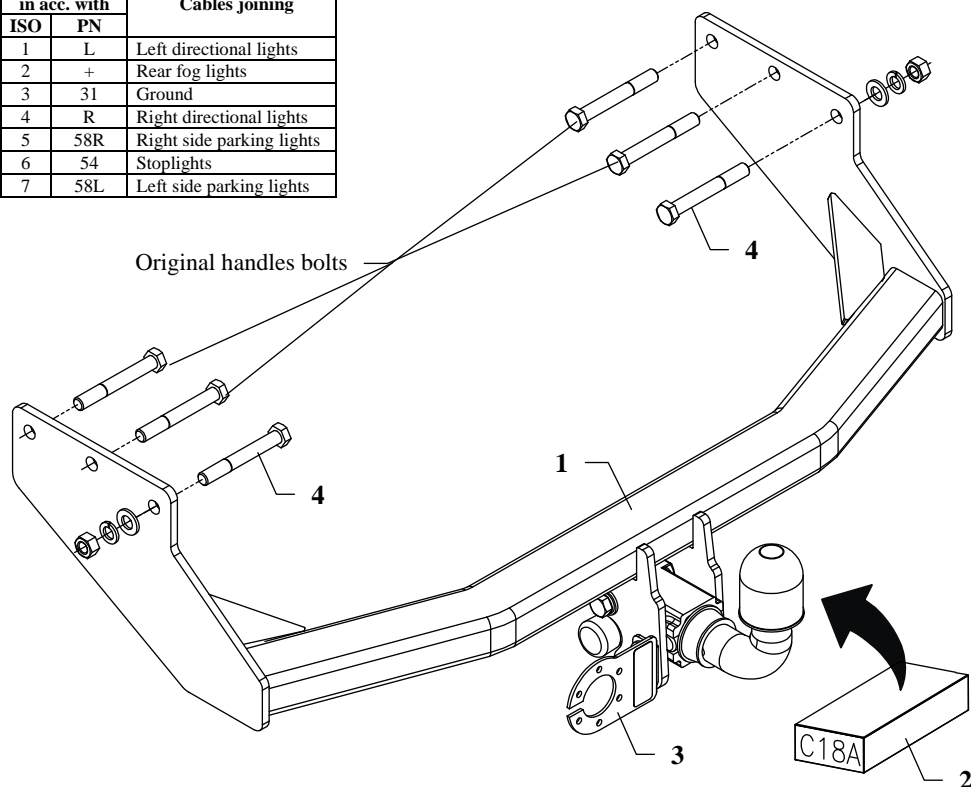

This towing hitch is designed to assembly in following cars:  
**FORD TRANSIT, metal build-up, also MAXI, loading platform,**  
 produced since 11.1991 till 04.2000, catalogue no. **C18A** and is prepared to  
 tow trailers max total weight **2000 kg** and max vertical mass **75 kg**.  
 Towbar is designed in way excluding disassemble, cut out or drill a bumper.

### *From manufacturer*

Thank you for buying our product. Their reliability has been confirmed in many tests. Reliability of towing hitch depends also on correct assembly and right operation. For this reasons we kindly ask to read carefully this instruction and apply to hints.

*The towing hitch should be install in points described by a car producer.*

## The instruction of the assembly

1. Take off a spare wheel and factory tow handles (not used any more).
2. Fix the main bar of the towing hitch (pos. 1) through factory made holes (in chassis) using bolts M12x90mm (pos. 4). (four bolts from original tow handles and two from the towing hitch accessories).
3. Fix body of the automat and place tow-ball according to supplied instruction. Note! Remember to place socket plate (pos. 3) as shown on the drawing 1.
4. Tighten all bolts according to the torque shown in the table.
5. Connect electric wires of 7-poles socket according to the instruction of the car. (Recommend to make at authorized service station).
6. Complete paint layer damaged during installation.

Torque settings for nuts and bolts (8,8):	
<b>M 8</b> - 25 Nm	<b>M 10</b> - 55 Nm
<b>M 12</b> - 85 Nm	<b>M 14</b> - 135 Nm







## NOTE

After install the towing hitch you should get adequate note in registration book (at authorised service station). The car should be equipped with:

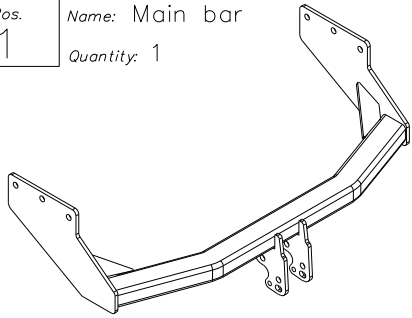
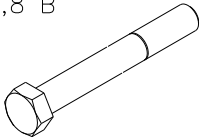
- Indicators
- Tow mirrors

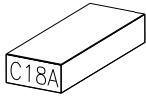
After 1000km of exploitation check all bolts and nuts. The ball of towing hitch must be always kept clear and conserve with a grease.

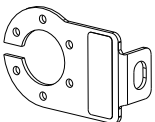
## Towing hitch accessories:

Pos. 1	Name: Main bar Quantity: 1		Pos. 4	Name: Bolt 8,8 B Quantity: 2 Dim. : M12x90mm	
			Pos. 5	Name: Nut 8 B Quantity: 2 Dim. : M12	
Pos. 2	Name: Tow ball Quantity: 1		Pos. 6	Name: Plain washer Quantity: 6 Dim. : Ø 13 mm	
Pos. 3	Name: Socket plate Quantity: 1		Pos. 7	Name: Spring washer Quantity: 6 Dim. : Ø 12,2 mm	



**PPUH AUTO-HAK S.J.**

Produkcja Zaczepów Kulowych  
Henryk i Zbigniew Nejman  
76-200 SŁUPSK ul. Słoneczna 16K  
tel/fax (059) 8-414-414; 8-414-413  
E-mail: [office@autohak.com.pl](mailto:office@autohak.com.pl)  
[www.autohak.com.pl](http://www.autohak.com.pl)

## Towing hitch (without electrical set)

Class: **A50-X** Cat. no. **C18A**

Designed for:

Manufacturer: **FORD**

Model: **TRANSIT**

Type: **metal build-up, also MAXI,  
loading platform,**

produced since 11.1991 till 04.2000

Technical data:

**D-value: 12,48 kN**

maximum trailer weight: **2000 kg**

maximum vertical cup mass: **75 kg**

**Approval number according to Directive 94/20/EC: e20\*94/20\*0975\*00**

## Foreword

This towing hitch is designed according to rules of safety traffic regulations. The towing hitch is a safety component and can be install only by qualified personnel. Any alteration or conversion of the towing hitch is prohibited and would lead to cancellation of design certification. Remove insulating compound and underseal from vehicle (if present) in the area of the matting surfaces of the towing hitch. The vehicle manufacturer's specifications regarding trailer mass and max. vertical cup mass are decisive for driving whereat values for the towing hitch cannot be exceeded.

*D-value formula:*

$$\frac{\text{Max trailer weight [kg]} \times \text{Max vehicle weight [kg]}}{\text{Max trailer weight [kg]} + \text{Max vehicle weight [kg]}} \times \frac{9,81}{1000} = D \text{ [kN]}$$