

FITTING INSTRUCTION

Clamp mark in acc. with		Cables joining
ISO	PN	
1	L	Left directional lights
2	+	Rear fog lights
3	31	Ground
4	R	Right directional lights
5	58R	Right side parking lights
6	54	Stoplights
7	58L	Left side parking lights

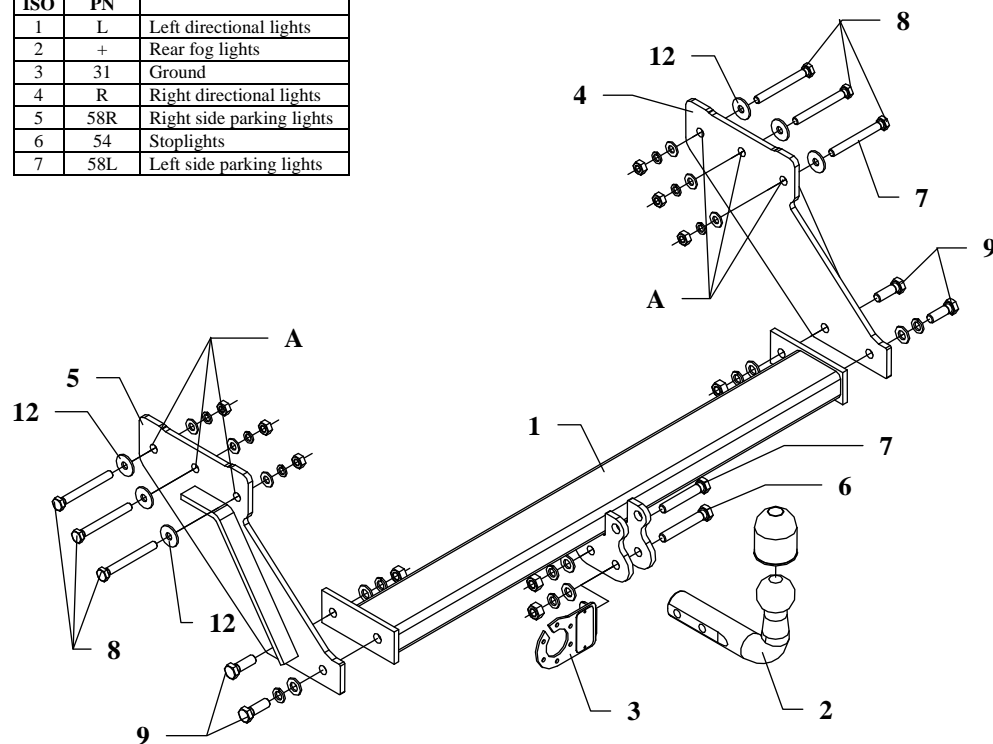

This towing hitch is designed to assembly in following cars: **FORD TRANSIT, metal built-up, loading platform**, produced since 1986 till 10.1991, catalogue no. **C17** and is prepared to tow trailers max total weight **2000 kg** and max vertical mass **75 kg**.

From manufacturer

Thank you for buying our product. Their reliability has been confirmed in many tests. Reliability of towing hitch depends also on correct assembly and right operation. For this reasons we kindly ask to read carefully this instruction and apply to hints.

The towing hitch should be install in points described by a car producer.

The instruction of the assembly

1. For the simplification of the assembly of the towbar one ought to take off the spare wheel.
2. On the left and right side of the chassis frame unscrew for two bolts fastening brackets of the bumper. On the right and left side of chassis frame unscrew additionally third bolt prepared by machinery to the assembly of the towbar (these bolts will not be used).
3. In dependence from the version and the foreseeing load of the car fix the main bar of the towing hitch (pos. 1) with brackets (pos. 4 and 5) as it shown on the figure a) or b):

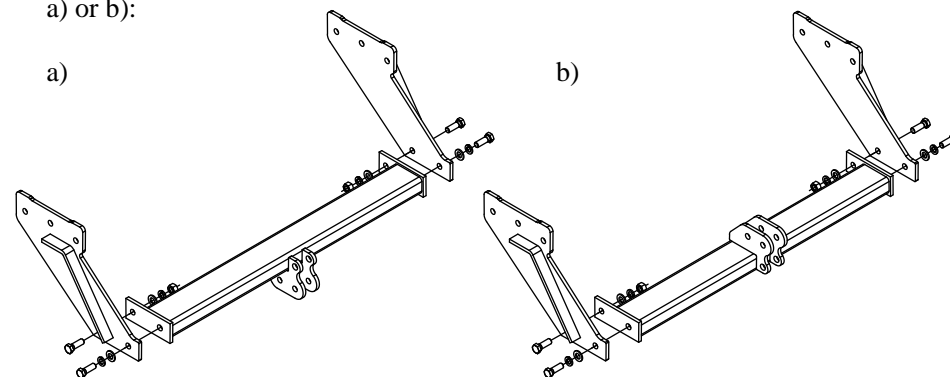

4. So prepared main bar of the towing hitch (pos. 1) apply underneath the car and through the holes of the towing hitch (pos. A) and brackets of the bumper fix to the frame of the car using bolts M10x90mm (pos. 8). Use washers (pos. 12).
5. Fix tow ball (pos. 2) using bolt M12x75mm (pos. 6) and M12x70mm (pos. 7). With bolt M12x75mm fix also a socket plate (pos. 3). See figure 1.
6. Tighten all bolts according to the torque shown in the table.
7. Connect electric wires of 7-poles socket according to the instruction of the car. (Recommend to make at authorized service station).
8. Complete paint layer damaged during installation.

Torque settings for nuts and bolts (8,8):	
M 8 - 25 Nm	M 10 - 55 Nm
M 12 - 85 Nm	M 14 - 135 Nm

NOTE

After install the towing hitch you should get adequate note in registration book (at authorised service station). The car should be equipped with:

- Indicators
- Tow mirrors

After 1000km check all bolts and nuts. The ball of towing hitch must be always kept clear and conserve with a grease.

Towing hitch accessories:

Pos. 1 Main bar PCS.: 1	Pos. 5 Left bracket PCS.: 1	Pos. 10 Nut 8 B M12 PCS.: 4	Pos. 15 Spring washer Ø12mm PCS.: 6
Pos. 2 Tow ball PCS.: 1	Pos. 6 Bolt 8,8 B M12x75mm PCS.: 1	Pos. 11 Nut 8 B M10 PCS.: 6	Pos. 16 Spring washer Ø10mm PCS.: 6
Pos. 3 Socket plate PCS.: 1	Pos. 7 Bolt 8,8 B M12x70mm PCS.: 1	Pos. 12 Washer Ø30xØ10.5x2.5mm PCS.: 6	Pos. 17 Ball cover PCS.: 1
Pos. 4 Right bracket PCS.: 1	Pos. 8 Bolt 8,8 B M10x90mm PCS.: 6	Pos. 13 Plain washer Ø12mm PCS.: 6	
	Pos. 9 Bolt 8,8 B M12x35mm PCS.: 4	Pos. 14 Plain washer Ø10mm PCS.: 6	



PPUH AUTO-HAK S.J.

Produkcja Zaczepów Kulowych
Henryk i Zbigniew Nejman
76-200 SŁUPSK ul. Słoneczna 16K
tel/fax (059) 8-414-414; 8-414-413
E-mail: office@autohak.com.pl
www.autohak.com.pl

Towing hitch (without electrical set)

Class: **A50-X** Cat. no. **C17**

Designed for:

Manufacturer: **FORD**

Model: **TRANSIT**

Type: **metal built-up, loading platform**

produced since 1986 till 10.1991

Technical data:

D-value: 11,66 kN

maximum trailer weight: **2000 kg**

maximum vertical cup mass: **75 kg**

Approval number according to Directive 94/20/EC: e20*94/20*0398*00

Foreword

This towing hitch is designed according to rules of safety traffic regulations. The towing hitch is a safety component and can be install only by qualified personnel. Any alteration or conversion of the towing hitch is prohibited and would lead to cancellation of design certification. Remove insulating compound and underseal from vehicle (if present) in the area of the matting surfaces of the towing hitch. The vehicle manufacturer's specifications regarding trailer mass and max. vertical cup mass are decisive for driving whereat values for the towing hitch cannot be exceeded.

D-value formula:

$$\frac{\text{Max trailer weight [kg]} \times \text{Max vehicle weight [kg]}}{\text{Max trailer weight [kg]} + \text{Max vehicle weight [kg]}} \times \frac{9,81}{1000} = D \text{ [kN]}$$