

FITTING INSTRUCTION

Clamp mark in acc. with		Cables joining
ISO	PN	
1	L	Left directional lights
2	+	Rear fog lights
3	31	Ground
4	R	Right directional lights
5	58R	Right side parking lights
6	54	Stoptlights
7	58L	Left side parking lights

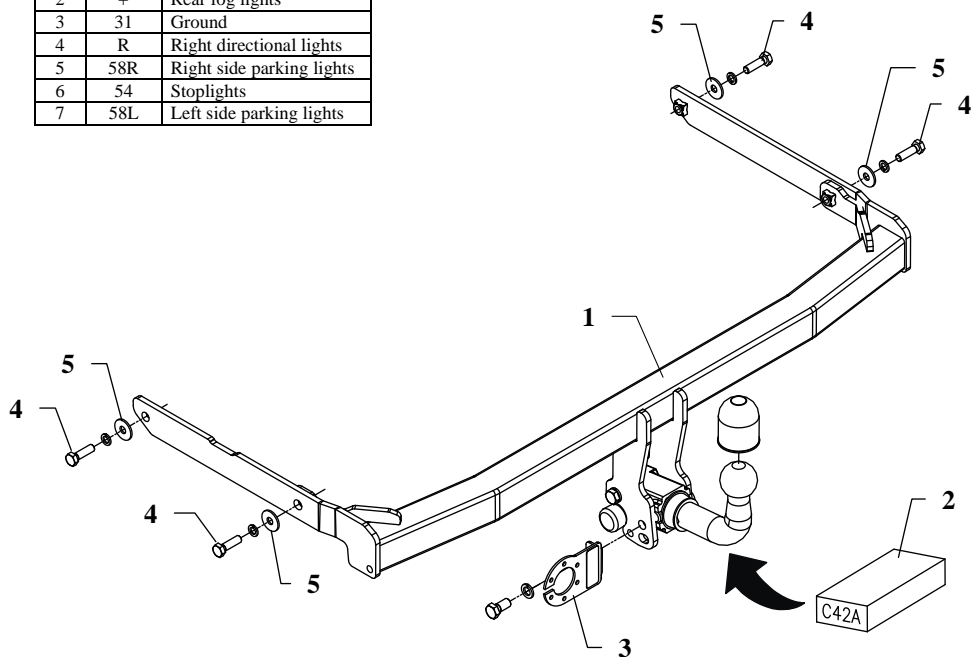

This towbar is designed to assembly in following cars: **FORD FIESTA, 3/5 doors, VAN, except Sport/ST150** produced since 05.2002 till 09.2005 and since 10.2005 till 08.2008, catalogue no. **C42A** and is prepared to tow trailers max total weight **900 kg** and max vertical mass **50 kg**.

From manufacturer

Thank you for buying our product. Their reliability has been confirmed in many tests. Reliability of towbar depends also on correct assembly and right operation. For this reasons we kindly ask to read carefully this instruction and apply to hints.

The towbar should be install in points described by a car producer.

The instruction of the assembly

1. Disassemble the rear bumper.
2. Slide the main bar of the towbar (pos. 1) to the chassis member and fit it using bolts M10x35mm (pos. 6) supplied with the towbar.
3. Cut the bumper according to the fig. 2 and then reassemble it.

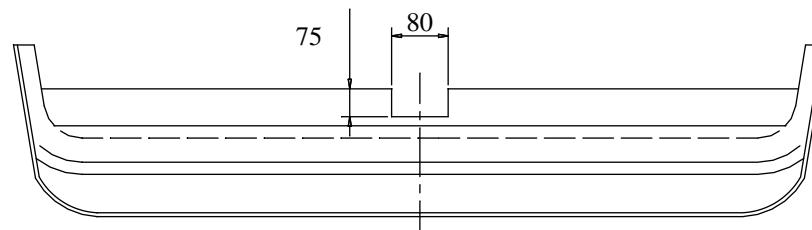

Fig. 2

4. Fix body of the automat and place tow-ball (pos. 2) according to supplied instruction.
5. Tighten all bolts according to the torque shown in the table.
6. Connect electric wires of 7-poles socket according to the instruction of the car. (Recommend to make at authorized service station).
7. Complete paint layer damaged during installation.

Torque settings for nuts and bolts (8,8):

M6 - 11 Nm	M8 - 25 Nm	M10 - 50 Nm
M12 - 87 Nm	M14 - 138 Nm	M16 - 210 Nm



NOTE

After install the towbar you should get adequate note in registration book (at authorised service station).The car should be equipped with:

- Indicators
- Tow mirrors

After 1000km of exploitation check all bolts and nuts. The ball of towbar must be always kept clear and conserve with a grease.

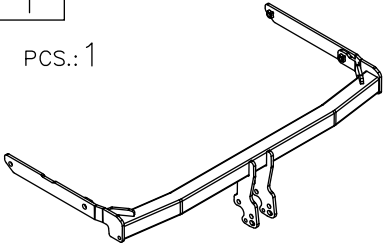
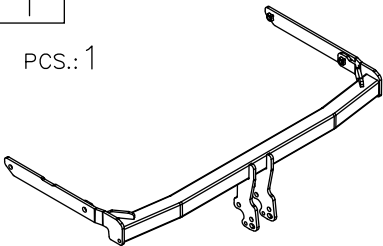
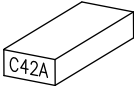
Towbar accessories:

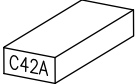
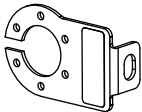
Pos. 1	Main bar	Pos. 4	Bolt 8,8 B M10x35mm	
PCS.: 1		PCS.: 4		
		Pos. 5	Plain washer ø30xø10,5x2,5mm	
		PCS.: 4		
Pos. 2	Tow ball (mounting set)	Pos. 6	Spring washer ø10,2mm	
PCS.: 1		PCS.: 4		
				
Pos. 3	Socket plate			
PCS.: 1				



PPUH AUTO-HAK Sp.J.

Produkcja Zaczepów Kulowych
Henryk i Zbigniew Nejman
76-200 SŁUPSK ul. Słoneczna 16K
tel/fax (059) 8-414-414; 8-414-413
E-mail: office@autohak.com.pl
www.autohak.com.pl

Towing hitch (without electrical set)

Class: **A50-X** Cat. no. **C42A**

Designed for:

Manufacturer: **FORD**

Model: **FIESTA**

Type: **3/5 doors VAN, except Sport/ST150**

produced since 05.2002 till 09.2005 and

since 10.2005 till 08.2008

Technical data:

D-value: 5,62 kN

maximum trailer weight: **900 kg**

maximum vertical cup load: **50 kg**

Approval number according to Directive 94/20/EC: e20*94/20*0923*00

Foreword

This towbar is designed according to rules of safety traffic regulations. The towing hitch is a safety component and can be install only by qualified personnel. Any alteration or conversion of the towing hitch is prohibited and would lead to cancellation of design certification. Remove insulating compound and underseal from vehicle (if present) in the area of the matting surfaces of the towing hitch. The vehicle manufacturer's specifications regarding trailer load and max. vertical cup load are decisive for driving whereat values for the towing hitch cannot be exceeded.

D-value formula:

$$\frac{\text{Max trailer weight [kg]} \times \text{Max vehicle weight [kg]}}{\text{Max trailer weight [kg]} + \text{Max vehicle weight [kg]}} \times \frac{9,81}{1000} = D \text{ [kN]}$$