

FITTING INSTRUCTION

Clamp mark in acc. with		Cables joining
ISO	PN	
1	L	Left directional lights
2	+	Rear fog lights
3	31	Ground
4	R	Right directional lights
5	58R	Right side parking lights
6	54	Stoplights
7	58L	Left side parking lights

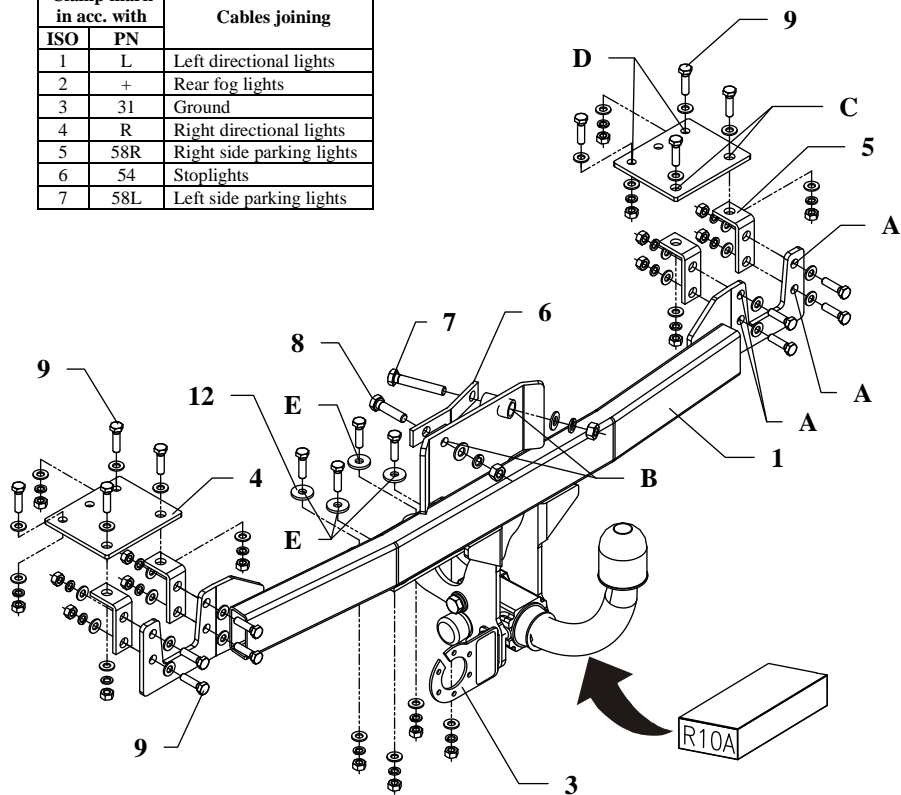

This towing hitch is designed to assembly in following cars: **FIAT BRAVO, 3 doors (182)**, produced since 09.1995 till 10.2001, catalogue no. **R10A** and is prepared to tow trailers max total weight **1400 kg** and max vertical load **75 kg**.

From manufacturer

Thank you for buying our product. Their reliability has been confirmed in many tests. Reliability of towing hitch depends also on correct assembly and right operation. For this reasons we kindly ask to read carefully this instruction and apply to hints.

The towing hitch should be installed in points described by a car producer.

The instruction of the assembly

1. Take out a spare wheel. Disassemble a bumper and remove his filling.
2. Inside trunk disassemble cover plates of sides and rear wall and take out felt-mat from spare wheel housing.
3. On the left and right side of rear wall twist off plugs off chassis members and remove rest of rivet.
4. Put main bar of the towing hitch (pos. 1) to rear wall (in axis) and then through holes (pos. A) drill holes using bit $\varnothing 9\text{mm}$.
5. Underneath a car put angle elements (pos. 5) and through holes (pos. A) fix with main bar using bolts M8x30mm (pos. 9).
6. Through holes (pos. B) drill using bit $\varnothing 11\text{mm}$ and next fix using bolt M10x40mm and bolt M10x60mm using angle fish-plate (pos. 6).
7. Underneath a car drill holes through points pos. C inside the trunk, use bit $\varnothing 9\text{mm}$.
8. Inside trunk put fish-plates (pos. 4) and through holes pos. C fix it by bolts M8x30mm (pos. 9).
9. Through holes pos. D of fish-plates make holes $\varnothing 9\text{mm}$ and fix by bolts M8x30mm (pos. 9) and washers.
10. Underneath a car through holes pos. E drill using bit $\varnothing 9\text{mm}$ and fix by bolts M8x30mm (pos. 9).
11. Cut out the bumper according to supplied template, then reassemble it to a car.
12. Fix body of the automat and place tow-ball according to supplied instruction. Note! Remember to place socket plate (pos. 3) as shown on the drawing 1.
13. Fix tight all bolts according to the torque shown in the table.
14. Connect electric wires of 7-poles socket according to the instruction of the car. (Recommend to make at authorized service station).
15. Complete paint layer damaged during installation.

Torque settings for nuts and bolts (8,8):	
M 8 - 25 Nm	M 10 - 55 Nm
M 12 - 85 Nm	M 14 - 135 Nm











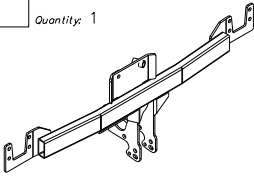
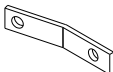

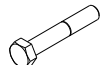
NOTE

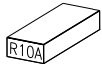
After install the towing hitch you should get adequate note in registration book (at authorised service station).The car should be equipped with:

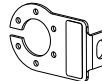
- Indicators
- Tow mirrors

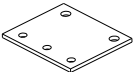
After 1000km check all bolts and nuts. The ball of towing hitch must be always kept clear and conserve with a grease.

Towing hitch equipment:

Pos. 1 Name: Main bar Quantity: 1 	Pos. 6 Name: Angle fish-plate Quantity: 1 	Pos. 12 Name: Washer Quantity: 4 Dim.: $\varnothing 25 \times \varnothing 9 \times 3 \text{mm}$ 
	Pos. 7 Name: Bolt 8,8 B Quantity: 1 Dim.: M10x60mm 	Pos. 13 Name: Plain washer Quantity: 2 Dim.: $\varnothing 10,5 \text{ mm}$ 
Pos. 2 Name: Tow ball Quantity: 1 	Pos. 8 Name: Bolt 8,8 B Quantity: 1 Dim.: M10x40mm 	Pos. 14 Name: Plain washer Quantity: 36 Dim.: $\varnothing 8,5 \text{ mm}$ 
Pos. 3 Name: Socket plate Quantity: 1 	Pos. 9 Name: Bolt 8,8 B Quantity: 20 Dim.: M8x30mm 	Pos. 15 Name: Spring washer Quantity: 2 Dim.: $\varnothing 10,2 \text{ mm}$ 
Pos. 4 Name: Fish-plate Quantity: 2 	Pos. 10 Name: Nut 8 B Quantity: 2 Dim.: M10 	Pos. 16 Name: Spring washer Quantity: 20 Dim.: $\varnothing 8,2 \text{ mm}$ 
Pos. 5 Name: Angle bar Quantity: 4 	Pos. 11 Name: Nut 8 B Quantity: 20 Dim.: M8 	



PPUH AUTO-HAK S.J.

Produkcja Haków Holowniczych
Henryk i Zbigniew Nejman
76-200 SŁUPSK ul. Słoneczna 16K
tel/fax (059) 8-414-414; 8-414-413
E-mail: office@autohak.com.pl
www.autohak.com.pl

Towing hitch (without electrical set)

Class: **A50-X** Cat. no. **R10A**

Designed for:

Manufacturer: **FIAT**

Model: **BRAVO**

Type: **3 doors (182)**

produced since 09.1995 till 10.2001

Technical data:

D-value: 7,9 kN

maximum trailer weight: **1400 kg**

maximum vertical cup load: **75 kg**

Approval number according to Directive 94/20/EC: **e20*94/20*0311*00**

Foreword

This towing hitch is designed according to rules of safety traffic regulations. The towing hitch is a safety component and can be install only by qualified personnel. Any alteration or conversion of the towing hitch is prohibited and would lead to cancellation of design certification. Remove insulating compound and underseal from vehicle (if present) in the area of the matting surfaces of the towing hitch. The vehicle manufacturer's specifications regarding trailer load and max. vertical cup load are decisive for driving whereat values for the towing hitch cannot be exceeded.

D-value formula:

$$\frac{\text{Max trailer weight [kg]} \times \text{Max vehicle weight [kg]}}{\text{Max trailer weight [kg]} + \text{Max vehicle weight [kg]}} \times \frac{9,81}{1000} = D \text{ [kN]}$$

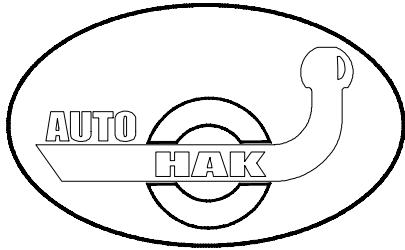

76-200 Słupsk. Ul Słoneczna 16 K

PPUH AUTO-HAK Sp.J.
Henryk i Zbigniew Nejman
ul. Słoneczna 16K
76-200 SŁUPSK, POLAND
tel/fax +48 059 8-414-414;
e-mail: office@autohak.com.pl
www.autohak.com.pl

*Template for towbar catalogue no. R10A
designed for FIAT BRAVO 3 doors,
produced since 09.1995 till 10.2001.*

