

FITTING INSTRUCTION

Clamp mark in acc. with		Cables joining
ISO	PN	
1	L	Left directional lights
2	+	Rear fog lights
3	31	Ground
4	R	Right directional lights
5	58R	Right side parking lights
6	54	Stoptlights
7	58L	Left side parking lights

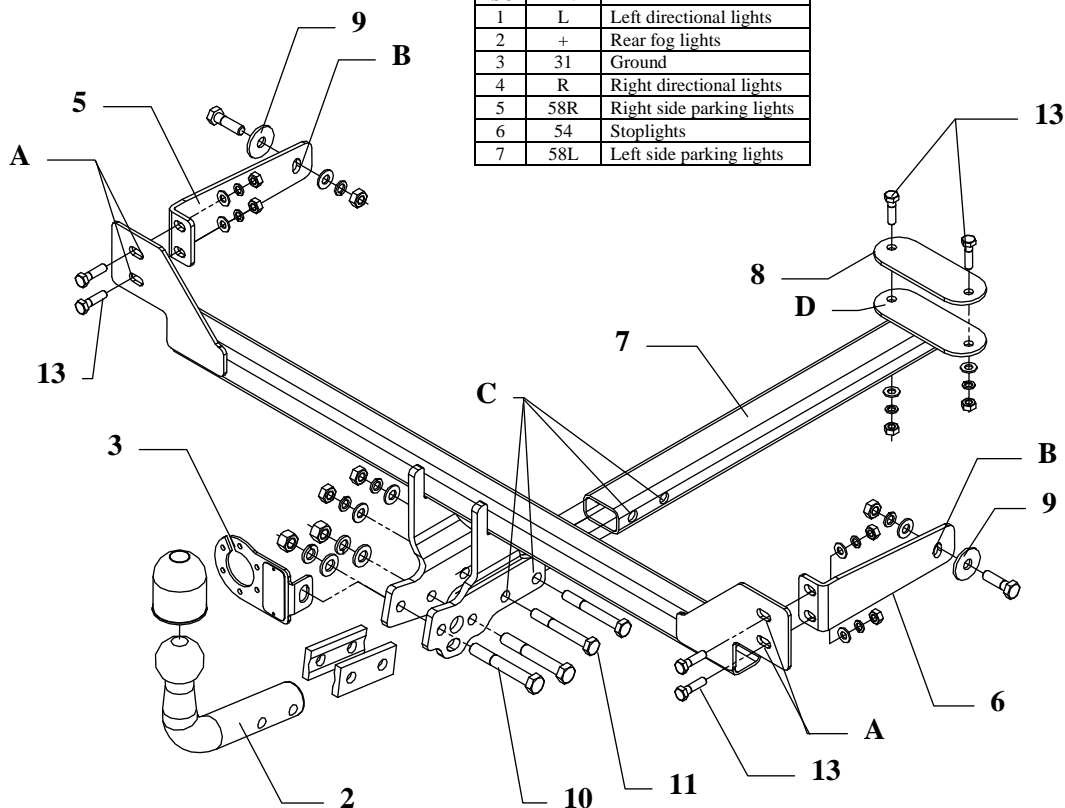

This towbar is designed to assembly in following cars:
FIAT UNO, 3/5 doors (146), produced since 01.1994 till 12.2002,
 catalogue no. **R23** and is prepared to tow trailers max total weight **1100 kg**
 and max vertical load **50 kg**.

From manufacturer

Thank you for buying our product. Their reliability has been confirmed in many tests. Reliability of towbar depends also on correct assembly and right operation. For this reasons we kindly ask to read carefully this instruction and apply to hints.

The towbar should be install in points described by a car producer.

The instruction of the assembly

1. Disassemble the bumper and take out the spare wheel.
2. Put the main bar of the towbar (pos. 1) between edges of rear panel in this way so bar stick to rear panel in central point. Mark holes (pos. A) on rear panel.
3. Marked points drill using bit $\varnothing 1$ mm.
4. Side brackets (pos. 5 and 6) put to recess on the left and right side of the chassis and fix by bolts M10x30mm (pos. 12) through existing holes (pos. B).
5. Put the main bar (pos. 1) to rear panel and fix through maked holes (pos. A) with mounted brackets (pos. 5 and 6).
6. Reinstall rear bumper.
7. Jib (pos. 7) fix through holes (pos. C) using bolts M10x80mm (pos. 11) and next drill to spare wheel recess holes (pos. D) using bit $\varnothing 9$ mm.
8. In spare wheel recess put fish-plate (pos. 8). Through maked holes (pos. D) fix it to bar (pos. 7) by bolts M8x30mm (pos. 13).
9. Fix tow-ball (pos. 2) and socket plate (pos. 3) using bolts M12x85mm (pos. 10) from accessories.
10. Tighten all bolts according to the torque shown in the table.
11. Connect electric wires of 7-poles socket according to the instruction of the car. (Recommend to make at authorized service station).
12. Complete paint layer damaged during installation.

Torque settings for nuts and bolts (8,8):	
M 8 - 25 Nm	M 10 - 55 Nm
M 12 - 85 Nm	M 14 - 135 Nm









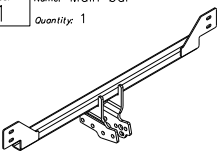

NOTE

After install the towbar you should get adequate note in registration book (at authorised service station).The car should be equipped with:

- Indicators
- Tow mirrors

After 1000km check all bolts and nuts. The ball of towbar must be always kept clear and conserve with a grease.

Towbar accessories:

Pos. 1 Name: Main bar Quantity: 1	Pos. 7 Name: Jib Quantity: 1	Pos. 14 Name: Nut 8 B Quantity: 2 Dim.: M12	Pos. 21 Name: Spring washer Quantity: 4 Dim.: \varnothing 10,2 mm
	Pos. 8 Name: Fish-plate Quantity: 1	Pos. 15 Name: Nut 8 B Quantity: 4 Dim.: M10	Pos. 22 Name: Spring washer Quantity: 6 Dim.: \varnothing 8,2 mm
	Pos. 9 Name: Plain washer Quantity: 2 Dim.: \varnothing 35x \varnothing 12x3mm	Pos. 16 Name: Nut 8 B Quantity: 6 Dim.: M8	Pos. 23 Name: Ball cover Quantity: 1
	Pos. 10 Name: Bolt 8.8 B Quantity: 2 Dim.: M12x85mm	Pos. 17 Name: Plain washer Quantity: 2 Dim.: \varnothing 13 mm	
Pos. 3 Name: Socket plate Quantity: 1	Pos. 11 Name: Bolt 8.8 B Quantity: 2 Dim.: M10x80mm	Pos. 18 Name: Plain washer Quantity: 4 Dim.: \varnothing 10,5 mm	
	Pos. 12 Name: Bolt 8.8 B Quantity: 2 Dim.: M10x30mm	Pos. 19 Name: Plain washer Quantity: 6 Dim.: \varnothing 8,5 mm	
Pos. 4 Name: Ball's fish-plate Quantity: 2	Pos. 13 Name: Bolt 8.8 B Quantity: 6 Dim.: M8x30mm	Pos. 20 Name: Spring washer Quantity: 2 Dim.: \varnothing 12,2 mm	
			
Pos. 5 Name: Left bracket Quantity: 1			
			
Pos. 6 Name: Right bracket Quantity: 1			
			



PPUH AUTO-HAK S.J.

Produkcja Haków Holowniczych
Henryk i Zbigniew Nejman
76-200 SŁUPSK ul. Słoneczna 16K
tel/fax (059) 8-414-414; 8-414-413
E-mail: office@autohak.com.pl
www.autohak.com.pl

Towing hitch (without electrical set)

Class: **A50-X** Cat. no. **R23**

Designed for:

Manufacturer: **FIAT**

Model: **UNO**

Type: **3/5 doors (146)**

produced since 01.1994 till 12.2002

Technical data:

D-value: 5,67 kN

maximum trailer weight: **1100 kg**

maximum vertical cup load: **50 kg**

Approval number acc. to regulations EKG/ONZ 55.01: E20-55R-01 1404

Foreword

This towbar is designed according to rules of safety traffic regulations. The towing hitch is a safety component and can be install only by qualified personnel. Any alteration or conversion of the towing hitch is prohibited and would lead to cancellation of design certification. Remove insulating compound and underseal from vehicle (if present) in the area of the matting surfaces of the towing hitch. The vehicle manufacturer's specifications regarding trailer load and max. vertical cup load are decisive for driving whereat values for the towing hitch cannot be exceeded.

D-value formula:

$$\frac{\text{Max trailer weight [kg]} \times \text{Max vehicle weight [kg]}}{\text{Max trailer weight [kg]} + \text{Max vehicle weight [kg]}} \times \frac{9,81}{1000} = D \text{ [kN]}$$