

FITTING INSTRUCTION

Clamp mark in acc. with		Cables joining
ISO	PN	
1	L	Left directional lights
2	+	Rear fog lights
3	31	Ground
4	R	Right directional lights
5	58R	Right side parking lights
6	54	Stoptlights
7	58L	Left side parking lights

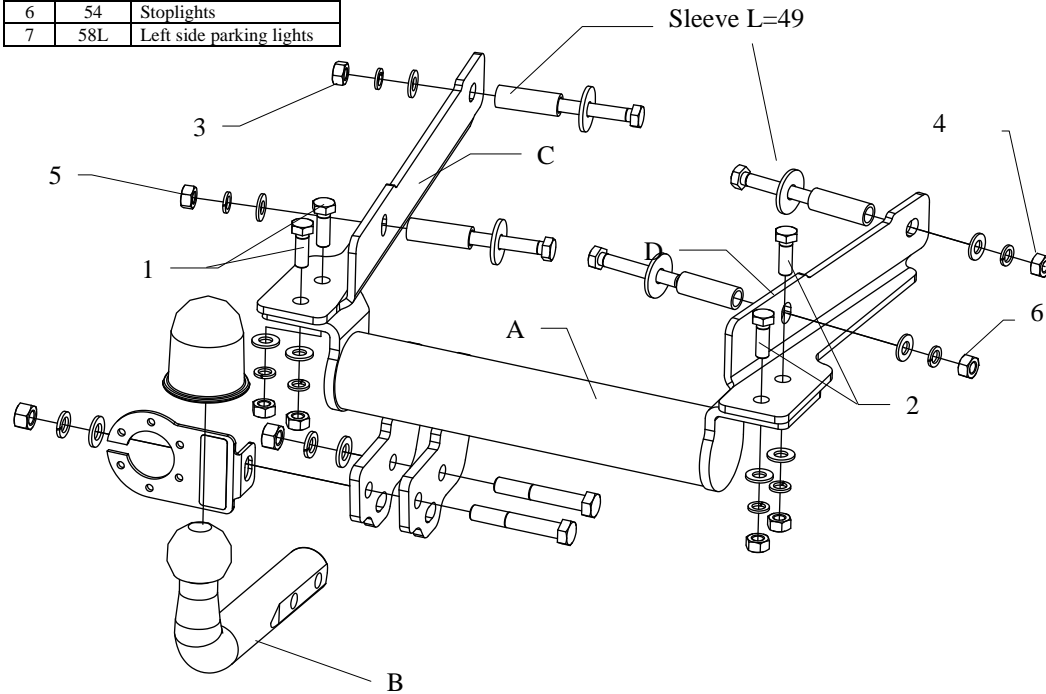

This towbar is designed to assembly in following car:

CITROEN AX 3/5 doors, except 4x4 catalogue no. **P01**, produced since 07.1986 till 12.1998 and is prepared to tow trailers max total weight **750 kg** and max vertical load **50 kg**.

Foreword

Thank you for buying our product. This towbar is design according to rules of safety traffic regulations and their reliability has been confirmed in many tests. Reliability of towbar also depends on correct assembly and correct exploitation. For this reasons we kindly ask to read carefully this instruction and apply to hints.

The towbar should be install in points described by a car producer.

The instruction of the assembly

1. To install our towbar You must take out a spare wheel.
2. In existing holes in chassis members put distance sleeves L=49mm (see drawing).
3. Through holes (pos. 1 and 2) in part poz. A, fix elements C and D using bolts M10x30mm and next put towbar (from below) to chassis members and through holes (pos. 3 and 4) and distance sleeves fix all using bolts M10x80mm (use washers too).
4. Through holes pos. 5 drill chassis member using bit $\varnothing 11\text{mm}$, and next put in existng hole (frim inside) distance sleeve L=44mm and fix all using bolt M10x70mm(use washer).
5. Through hole pos. 6 drill chassis member using bit $\varnothing 11\text{mm}$, and next, from inside, enlarge this hole using bit $\varnothing 17\text{mm}$. Next slip in hole distance sleeve L=44mm and fix all using bolt M10x70mm (use washer).
6. Fix tow-ball (pos. B) and socket plate using bolts M12x75mm from equipment.
7. Tighten all bolts according to the torque shown in the table.
8. Connect electric wires of 7-bolts socket according to the instruction of the car. (Recommend to make at authorized service station)
9. Complete the paint coating damaged during installation.

Torque settings for nuts and bolts (8,8):

M6 - 11 Nm	M8 - 25 Nm	M10 - 50 Nm
M12 - 87 Nm	M14 - 138 Nm	M16 - 210 Nm

NOTE

After install the towbar you should get adequate registration in registration book (at authorised service station).The car should be equipped with:

- Indicators
- Tow mirrors

After 1000km of exploitation check all bolts and nuts. The ball of towbar must be always kept clear and conserve with a grease.



PPUH AUTO-HAK Sp. J.

Produkcja Zaczepów Kulowych
Henryk i Zbigniew Nejman
76-200 SŁUPSK ul. Słoneczna 16K
tel/fax (059) 8-414-414; 8-414-413
E-mail: office@autohak.com.pl
www.autohak.com.pl

Towing hitch (without electrical set)

Class: **A50-X** Cat. no. **P01**

Designed for:

Manufacturer: **CITROEN**

Model: **AX**

Type: **3/5 doors except 4x4**

produced since 07.1986 till 12.1998

Technical data:

D-value: 4,43 kN

maximum trailer weight: **750 kg**

maximum vertical cup mass: **50 kg**

Approval number according to Directive 94/20/EC: e20*94/20*1348*00

Foreword

This towing hitch is designed according to rules of safety traffic regulations. The towing hitch is a safety component and can be install only by qualified personnel. Any alteration or conversion of the towing hitch is prohibited and would lead to cancellation of design certification. Remove insulating compound and underseal from vehicle (if present) in the areas of the matting surfaces of the towing hitch.

The vehicle manufacturer's specifications regarding trailer load and max. vertical cup mass are decisive for driving whereat values for the towing hitch cannot be exceeded.

D-value formula:

$$\frac{\text{Max trailer weight [kg]} \times \text{Max vehicle weight [kg]}}{\text{Max trailer weight [kg]} + \text{Max vehicle weight [kg]}} \times \frac{9,81}{1000} = D \text{ [kN]}$$