

FITTING INSTRUCTION

Clamp mark in acc. with		Cables joining
ISO	PN	
1	L	Left directional lights
2	+	Rear fog lights
3	31	Ground
4	R	Right directional lights
5	58R	Right side parking lights
6	54	Stoplights
7	58L	Left side parking lights

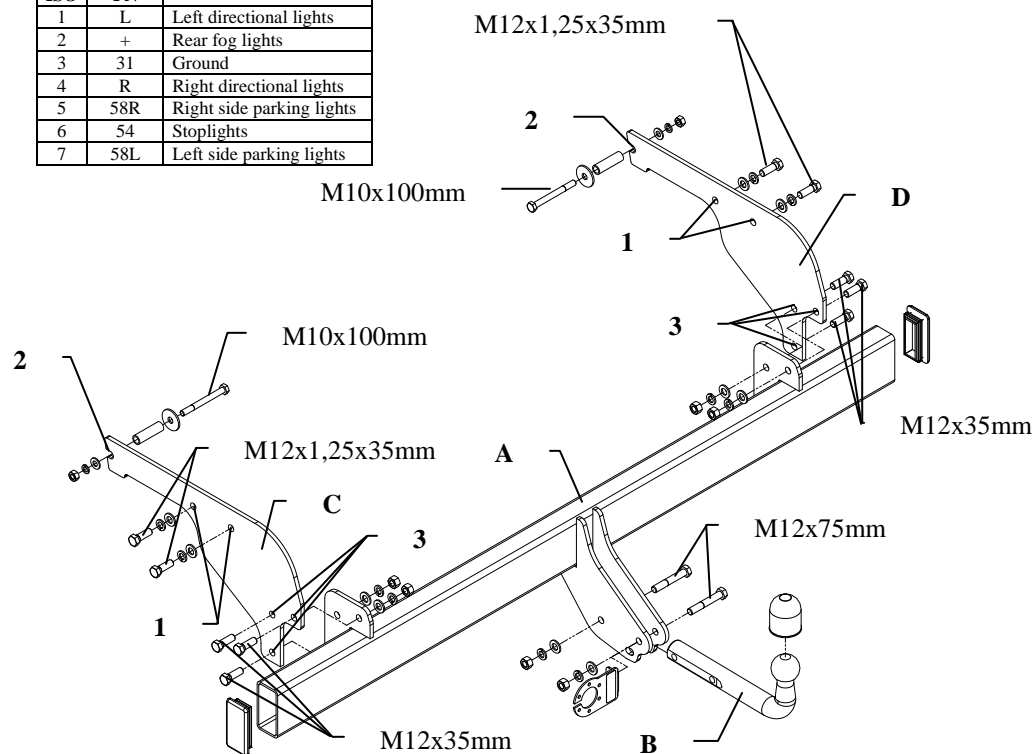

This towing hitch is designed to assembly in following cars:
TOYOTA HILUX, Pick up, 4WD, (N16, N17), with stepboard, produced since 10.1997 till 09.2005, catalogue no. **O57** and is prepared to tow trailers max total weight **2525 kg** and max vertical load **90 kg**.

From manufacturer

Thank you for buying our product. Their reliability has been confirmed in many tests. Reliability of towing hitch depends also on correct assembly and right operation. For this reasons we kindly ask to read carefully this instruction and apply to hints.

The towing hitch should be install in points described by a car producer.

The instruction of the assembly

1. Put side brackets (pos. C and D) to chassis frame (from outside) and next through holes pos. 1 and existing, threaded holes in frame screw it using bolts M12x1,25x35mm from equipment.
2. Through cut (pos. 2) fix brackets using bolts M10x100mm as shown in the drawing (to make this operation more easily you can get lower a spare wheel).
3. Between fixed brackets put (suitably) main bar of towing hitch (pos. A) and next through holes (pos. 3) screw all using bolts M12x35mm from towing hitch equipment.
4. Screw tow-ball (pos. B) and socket plate using bolts M12x75mm from equipment.
5. Tighten all bolts according to the torque shown in the table.
6. Connect electric wires of 7-bolts socket according to the instruction of the car. (Recommend to make at authorized service station)
7. Complete the paint coating damaged during instalment.

Torque settings for nuts and bolts (8,8):

M 8	25 Nm	M 10	55 Nm
M 12	85 Nm	M 14	135 Nm

NOTE

After install the towing hitch you should get adequate registration in registration book (at authorised service station).The car should be equipped with:

- Trafficators
- Tow mirrors

After 1000km check all bolts and nuts. The ball of towing hitch must be always kept clear and conserve with a grease.



PPUH AUTO-HAK S.J.

Produkcja Zaczepów Kulowych
Henryk i Zbigniew Nejman
76-200 SŁUPSK ul. Słoneczna 16K
tel/fax (059) 8-414-414; 8-414-413
E-mail: office@autohak.com.pl
www.autohak.com.pl

Towing hitch (without electrical set)

Class: **A50-X** Cat. no. **O57**

Designed for:

Manufacturer: **TOYOTA**

Model: **HILUX**

Type: **Pick-up, 4WD, (N16, N17), with stepboard**

produced since 10.1997 till 09.2005

Technical data:

D-value: 12,25 kN

maximum trailer weight: **2525 kg**

maximum vertical cup mass: **90 kg**

Approval number according to Directive 94/20/EC: e20*94/20*0456*00

Foreword

This towing hitch is designed according to rules of safety traffic regulations. The towing hitch is a safety component and can be install only by qualified personnel. Any alteration or conversion of the towing hitch is prohibited and would lead to cancellation of design certification. Remove insulating compound and underseal from vehicle (if present) in the area of the matting surfaces of the towing hitch.

The vehicle manufacturer's specifications regarding trailer mass and max. vertical cup mass are decisive for driving whereat values for the towing hitch cannot be exceeded.

D-value formula:

$$\frac{\text{Max trailer weight [kg]} \times \text{Max vehicle weight [kg]}}{\text{Max trailer weight [kg]} + \text{Max vehicle weight [kg]}} \times \frac{9,81}{1000} = D \text{ [kN]}$$