

FITTING INSTRUCTION

Clamp mark in acc. with		Cables joining
ISO	PN	
1	L	Left directional lights
2	+	Rear fog lights
3	31	Ground
4	R	Right directional lights
5	58R	Right side parking lights
6	54	Stoplights
7	58L	Left side parking lights

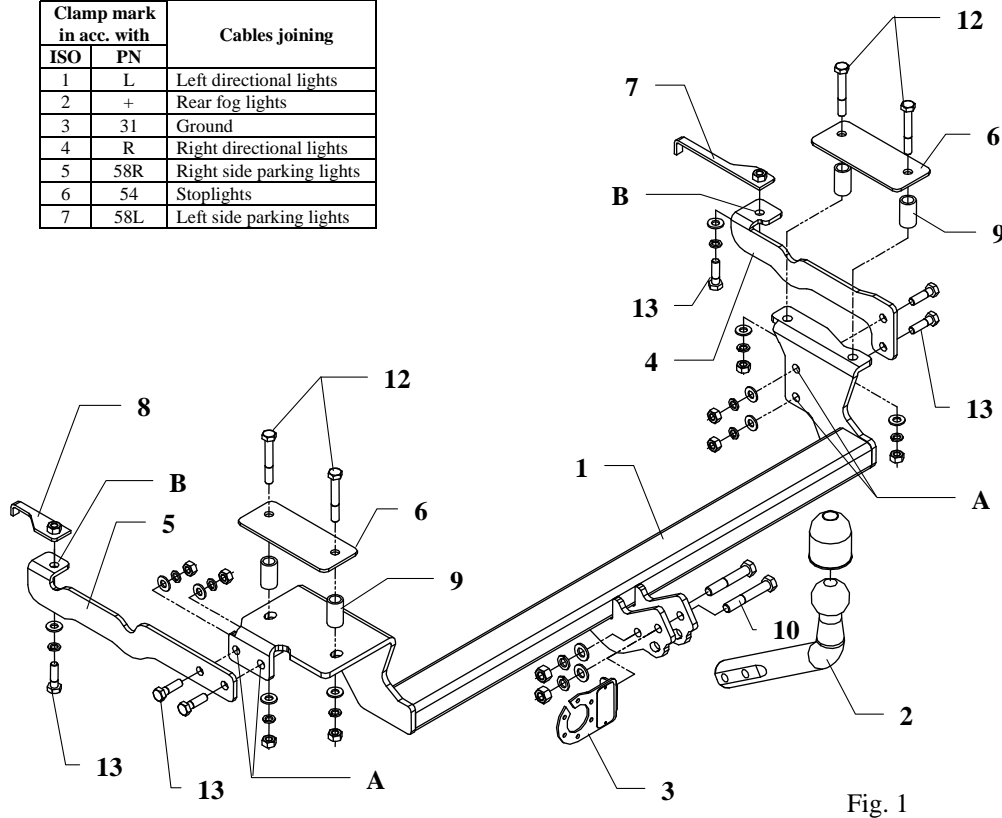

Fig. 1

This towing hitch is designed to assembly in following cars:
SEAT CORDOBA, 2/4 doors, produced since 02.1993 till 01.1996,
 catalogue no. **SC40** and is prepared to tow trailers max total weight
1200 kg and max vertical load **50 kg**.

From manufacturer

Thank you for buying our product. Their reliability has been confirmed in many tests. Reliability of towing hitch depends also on correct assembly and right operation. For this reasons we kindly ask to read carefully this instruction and apply to hints.

The towing hitch should be install in points described by a car producer.

The instruction of the assembly

- Underneath the car disassemble plastic cover;
 - in left and right chassis frame are four plugged holes $\varnothing 13\text{mm}$ (2 per each side) and per one longitudinal hole. Make it open and through holes $\varnothing 13\text{mm}$ drill holes inside the boot.

CAUTION! Remove floor carpet (in boot) before drill.

- Drill again holes only from inside boot using bit $\varnothing 22\text{mm}$. To drilled holes put distance sleeves $\varnothing 22$, $L=37\text{mm}$ (pos. 9), and top put fish-plates (pos. 6) as shown on the drawing. Insert bolts $M10 \times 70\text{mm}$ (pos. 12).
- On prominent bolt put main bar of the towbar (pos. 1) and fix loosely.
- Fix side brackets (pos. 4 and 5) as show on the drawing using bolts $M10 \times 35\text{mm}$ (pos. 13) through holes A. Fix by bolts $M10 \times 35\text{mm}$ (pos. 13) through holes B with jibs (pos. 7 and 8). Jibs place inside chassis frames through longitudinal holes.
- Fix tow ball (pos. 2) using bolt $M12 \times 75\text{mm}$ (pos. 10) and $M12 \times 70\text{mm}$ (pos. 11). With bolt $M12 \times 75\text{mm}$ fix also a socket plate (pos. 3). See figure 1.
- Tighten all bolts according to the torque shown in the table.
- Reassemble the cover after cut fragment as shown on figure 2.
- Connect electric wires of 7-poles socket according to the instruction of the car. (Recommend to make at authorized service station)
- Complete paint layer damaged during installation.

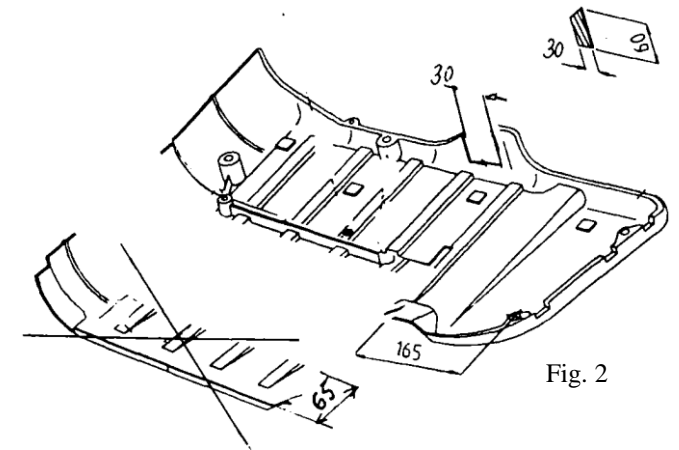

Fig. 2

Torque settings for nuts and bolts (8,8):	
M 8 - 25 Nm	M 10 - 55 Nm
M 12 - 85 Nm	M 14 - 135 Nm











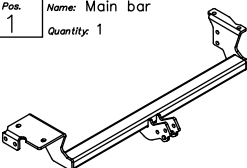
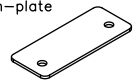
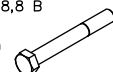

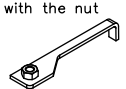

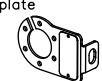

NOTE

After installation of a towing hitch you should get adequate note in registration book (at authorised service station). The car should be equipped with:

- Indicators
- Tow mirrors

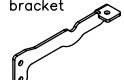
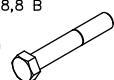
After 1000km of exploitation check all bolts and nuts. The ball of towing hitch must be always kept clear and conserve with a grease.

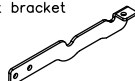
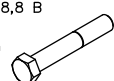
Towing hitch accessories:

Pos. 1 Name: Main bar Quantity: 1 	Pos. 6 Name: Fish-plate Quantity: 2 	Pos. 12 Name: Bolt 8,8 B Quantity: 4 Dim.: M10x70mm 	Pos. 18 Name: Spring washer Quantity: 2 Dim.: Ø 12,2 mm 
	Pos. 7 Name: Jib with the nut Quantity: 1 Dim.: M10 RIGHT 	Pos. 13 Name: Bolt 8,8 B Quantity: 6 Dim.: M10x35mm 	Pos. 19 Name: Spring washer Quantity: 10 Dim.: Ø 10,2 mm 
Pos. 2 Name: Tow ball Quantity: 1 	Pos. 8 Name: Jib with the nut Quantity: 1 Dim.: M10 LEFT 	Pos. 14 Name: Nut 8 B Quantity: 2 Dim.: M12 	Pos. 20 Name: Ball cover Quantity: 1 
Pos. 3 Name: Socket plate Quantity: 1 	Pos. 9 Name: Distance sleeve Quantity: 4 Dim.: Ø21.2x2.35mm L=37mm 	Pos. 15 Name: Nut 8 B Quantity: 8 Dim.: M10 	Pos. 21 Name: Rivet Quantity: 2 Dim.: Ø4mm 
Pos. 4 Name: Right bracket Quantity: 1 	Pos. 10 Name: Bolt 8,8 B Quantity: 1 Dim.: M12x75mm 	Pos. 16 Name: Plain washer Quantity: 2 Dim.: Ø 13 mm 	
Pos. 5 Name: Left bracket Quantity: 1 	Pos. 11 Name: Bolt 8,8 B Quantity: 1 Dim.: M12x70mm 	Pos. 17 Name: Plain washer Quantity: 10 Dim.: Ø 10,5 mm 	



PPUH AUTO-HAK Sp.J.

Produkcja Zaczepów Kulowych
Henryk i Zbigniew Nejman
76-200 SŁUPSK ul. Słoneczna 16K
tel/fax (059) 8-414-414; 8-414-413
E-mail: office@autohak.com.pl
www.autohak.com.pl

Towing hitch (without electrical set)

Class: **A50-X** Cat. no. **SC40**

Designed for:

Manufacturer: **SEAT**

Model: **CORDOBA**

Type: **2/4 doors**

produced since 02.1993 till 01.1996

Approval number according to Directive 94/20/EC:

e20*94/20*0206*00

Technical data:

D-value: 6,73 kN

maximum trailer weight: **1200 kg**

maximum vertical cup load: **50 kg**

Foreword

This towing hitch is designed according to rules of safety traffic regulations. The towing hitch is a safety component and can be install only by qualified personnel. Any alteration or conversion of the towing hitch is prohibited and would lead to cancellation of design certification. Remove insulating compound and underseal from vehicle (if present) in the area of the matting surfaces of the towing hitch. The vehicle manufacturer's specifications regarding trailer mass and max. vertical cup mass are decisive for driving whereat values for the towing hitch cannot be exceeded.

D-value formula:

$$\frac{\text{Max trailer weight [kg]} \times \text{Max vehicle weight [kg]}}{\text{Max trailer weight [kg]} + \text{Max vehicle weight [kg]}} \times \frac{9,81}{1000} = D \text{ [kN]}$$