

## FITTING INSTRUCTION

Clamp mark in acc. with		Cables joining
ISO	PN	
1	L	Left directional lights
2	+	Rear fog lights
3	31	Ground
4	R	Right directional lights
5	58R	Right side parking lights
6	54	Stoplights
7	58L	Left side parking lights

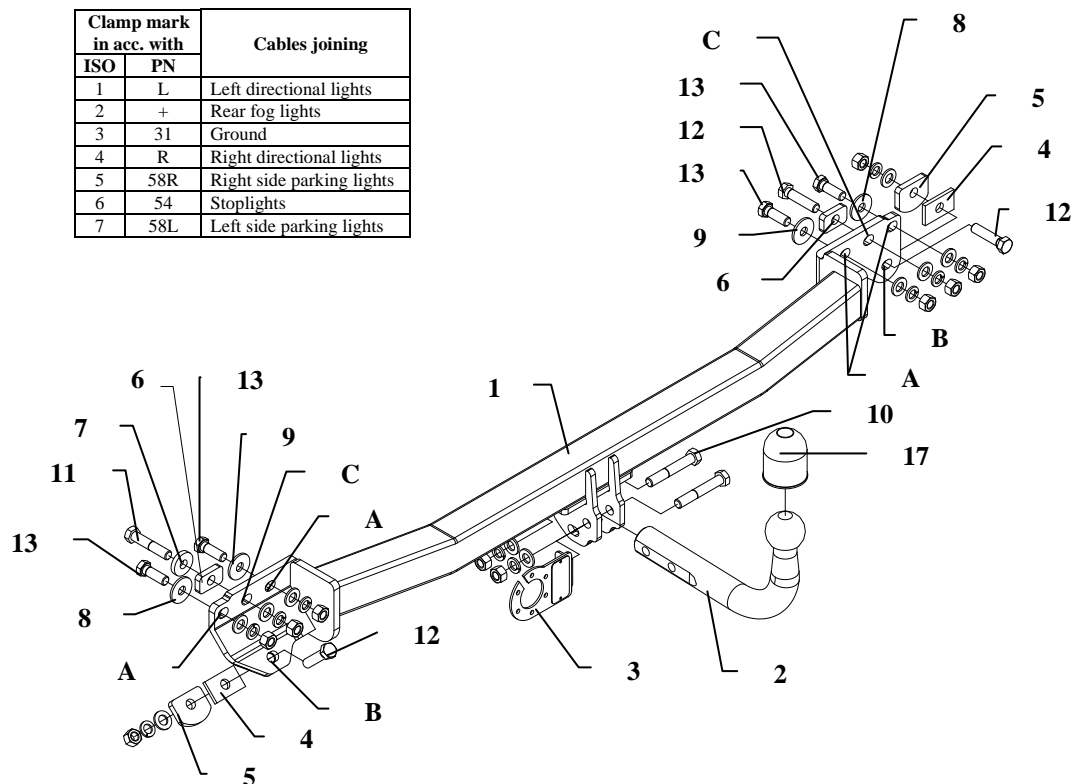

Fig.1

This towing hitch is designed to assembly in following cars:  
**NISSAN PRIMERA ESTATE (W10)**, produced since 07.1990 till 04.1998, catalogue number **V57** and is prepared to tow trailers max total weight **1500 kg** and max vertical load **75 kg**.

### Foreword

Thank you for buying our product. This towing hitch is design according to rules of safety traffic regulations and their reliability has been confirmed in many tests. Reliability of towing hitch also depends on correct assembly and correct exploitation. For this reasons we kindly ask to read carefully this instruction and apply to hints.

*The towing hitch should be install in points described by a car producer.*

## The instruction of the assembly

1. Disassemble a bumper and metal reinforcement of bumper (not used any more).
2. Put towing hitch (pos. 1) to rear part of car in that way so holes (pos. A) agree with protruding pins and holes (pos. B) with original tow brackets. In point (pos. B) fix using bolts M12x50mm, use washers (pos. 4 and 5). NOTE! Tight close towing hitch to rear part and tow brackets.
3. Remove four small bolts (pos. A) (break welds), and next drill holes of towing hitch (pos. A and C) using bit  $\varnothing 13$  mm.
4. Fix towing hitch through drilled holes – see fig. 1 (use distance washer (pos. 6) in point C).
5. Tighten all bolts according to the torque shown in the table.
6. Fix tow-ball (pos. 2) and socket plate (pos. 3 ) using bolts M12x75mm (pos. 10) from equipment.
7. Connect electric wires of 7-bolts socket according to the instruction of the car. (Recommend to make at authorized service station)
8. Complete the paint coating damaged during installation.

Torque settings for nuts and bolts (8,8):

<b>M6</b> - 11 Nm	<b>M8</b> - 25 Nm	<b>M10</b> - 50 Nm
<b>M12</b> - 87 Nm	<b>M14</b> - 138 Nm	<b>M16</b> - 210 Nm









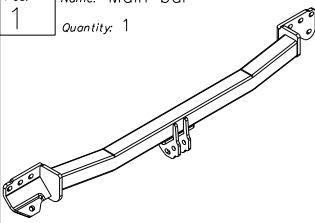

### NOTE

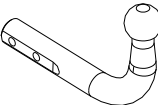
After install the towing hitch you should get adequate registration in registration book (at authorised service station).The car should be equipped with:

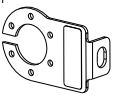
- Indicators
- Tow mirrors

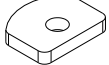
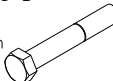
After 1000km of exploitation check all bolts and nuts. The ball of towing hitch must be always kept clear and conserve with a grease.

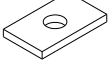
## Towing hitch equipment:

Pos. 1	Name: Main bar Quantity: 1	Pos. 6	Name: Rectangular washer Quantity: 2	Pos. 12	Name: Bolt 8,8 B Quantity: 3 Dim.: M12x50 mm
		Pos. 7	Name: Plain washer Quantity: 1 Dim.: Ø33xØ13x6mm	Pos. 13	Name: Bolt 8,8 B Quantity: 4 Dim.: M12x35 mm
					
Pos. 2	Name: Ball Quantity: 1	Pos. 8	Name: Washer Quantity: 2 Dim.: Ø35xØ12x4mm	Pos. 14	Name: Nut 8 B Quantity: 10 Dim.: M12
					
Pos. 3	Name: Socket plate Quantity: 1	Pos. 9	Name: Washer Quantity: 2 Dim.: Ø35xØ12x3mm	Pos. 15	Name: Washer Quantity: 10 Dim.: Ø13mm
					
Pos. 4	Name: Semicircular washer Quantity: 2	Pos. 10	Name: Bolt 8,8 B Quantity: 2 Dim.: M12x75 mm	Pos. 16	Name: Spring washer Quantity: 10 Dim.: Ø12,2mm
					
Pos. 5	Name: Rectangular washer Quantity: 2	Pos. 11	Name: Bolt 8,8 B Quantity: 1 Dim.: M12x60 mm	Pos. 17	Name: Ball cover Quantity: 1
					



## PPUH AUTO-HAK Sp.J.

Produkcja Zaczepów Kulowych  
Henryk i Zbigniew Nejman  
76-200 SŁUPSK ul. Słoneczna 16K  
tel/fax (059) 8-414-414; 8-414-413  
E-mail: [office@autohak.com.pl](mailto:office@autohak.com.pl)  
[www.autohak.com.pl](http://www.autohak.com.pl)

### Towing hitch (without electrical set)

Class: **A50-X** Cat. no. **V57**  
Designed for:  
Manufacturer: **NISSAN**  
Model: **PRIMERA**  
Type: **KOMBI (W10)**  
produced since 07.1990 till 04.1998

Technical data:  
**D-value: 8,12 kN**  
maximum trailer weight: **1500 kg**  
maximum vertical cup mass: **75 kg**

Approval number according to Directive 94/20/EC: **e20\*94/20\*0360\*00**

### Foreword

This towing hitch is designed according to rules of safety traffic regulations. The towing hitch is a safety component and can be install only by qualified personnel. Any alteration or conversion of the towing hitch is prohibited and would lead to cancellation of design certification. Remove insulating compound and underseal from vehicle (if present) in the area of the matting surfaces of the towing hitch. The vehicle manufacturer's specifications regarding trailer mass and max. vertical cup mass are decisive for driving whereat values for the towing hitch cannot be exceeded.

*D-value formula:*

$$\frac{\text{Max trailer weight [kg]} \times \text{Max vehicle weight [kg]}}{\text{Max trailer weight [kg]} + \text{Max vehicle weight [kg]}} \times \frac{9,81}{1000} = D \text{ [kN]}$$