

FITTING INSTRUCTION

Clamp mark in acc. with		Cables joining
ISO	PN	
1	L	Left directional lights
2	+	Rear fog lights
3	31	Ground
4	R	Right directional lights
5	58R	Right side parking lights
6	54	Stoplights
7	58L	Left side parking lights

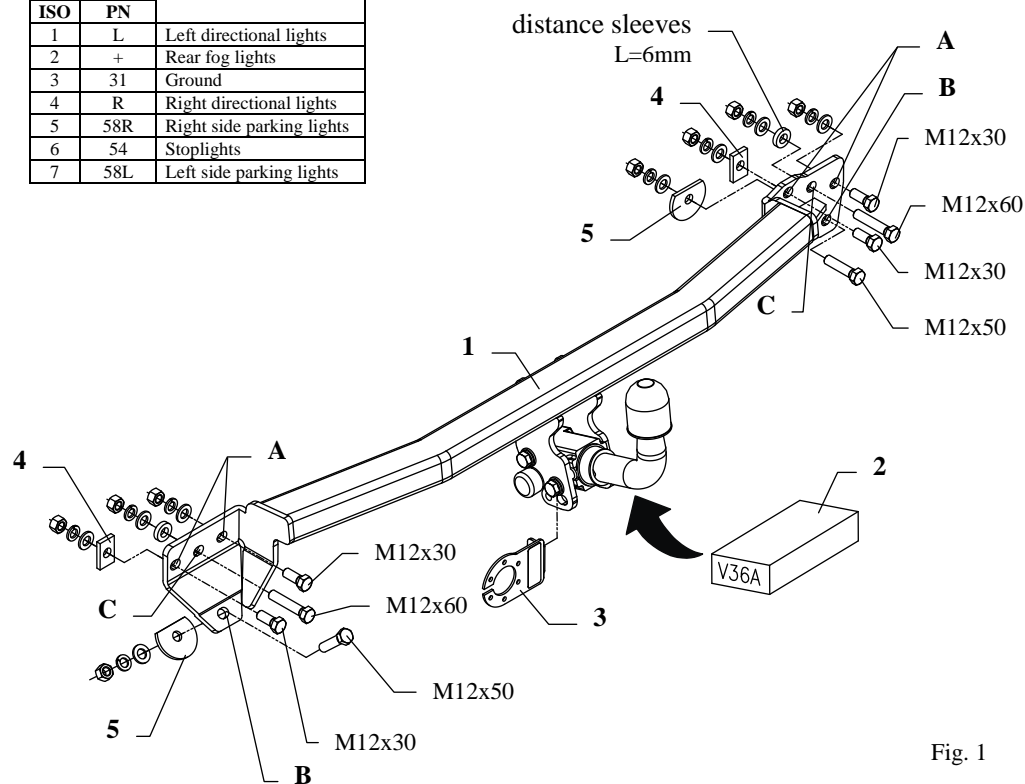

Fig. 1

This towbar is designed to assembly in following cars:
NISSAN SUNNY Traveller ESTATE (Y10), except 4x4, produced since 04.1991 till 12.2000, catalogue no. **V36A** and is prepared to tow trailers max total weight **1600 kg** and max vertical mass **75 kg**.

From manufacturer

Thank you for buying our product. Their reliability has been confirmed in many tests. Reliability of towbar depends also on correct assembly and right operation. For this reasons we kindly ask to read carefully this instruction and apply to hints.

The towbar should be install in points described by a car producer.

The instruction of the assembly

1. Unscrew the plastic bumper and then cut off the fragment from it, as shown on the fig. 2.
2. Unscrew the metal part of the bumper and then remove four bolts from points (pos. A, see the fig. 1) (use the angular polishing to remove). In the axis of symmetry cut out the fragment 80x55mm, as shown on the fig. 3.
3. Apply the main bar of the towbar (pos. 1) to the back piece and fix through holes (pos. B) using bolts M12x50mm (pos. 8) together with truncate washer (pos. 5).
4. Place four bolts M12x30mm (pos. 9) in holes (pos. A) – do not fix!
5. Through holes (pos. C) drill holes $\varnothing 13\text{mm}$ and then fix with bolts M12x60mm (pos. 7). Use distance sleeves (pos. 6), as shown on the fig. 1.
6. Remove bolts M12x30mm (pos. 9) from holes (pos. A) and then apply the metal bumper and fix with washer (pos. 4) using bolts M12x30mm (pos. 10).
7. Fix the plastic bumper.
8. Fix body of the automat and place tow-ball according to supplied instruction. Note! Remember to place socket plate (pos. 3) as shown on the drawing 1.
9. Tighten all bolts according to the torque shown in the table.
10. Connect electric wires of 7-poles socket according to the instruction of the car. (Recommend to make at authorized service station).
11. Complete paint layer damaged during installation.

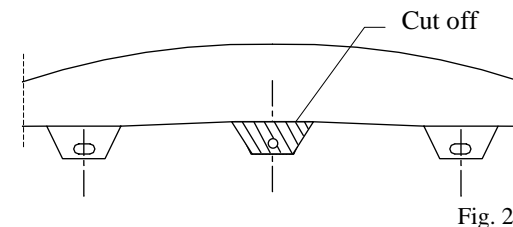

Fig. 2

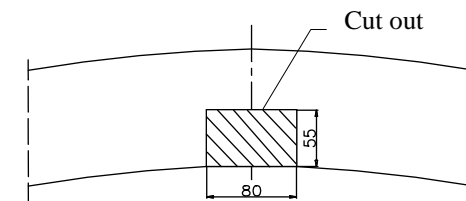

Fig. 3

Torque settings for nuts and bolts (8,8):	
M 8 - 25 Nm	M 10 - 55 Nm
M 12 - 85 Nm	M 14 - 135 Nm







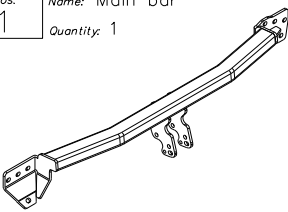

NOTE

After install the towbar you should get adequate note in registration book (at authorised service station). The car should be equipped with:

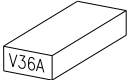
- Indicators
- Tow mirrors

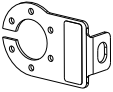
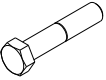
After 1000km of exploitation check all bolts and nuts. The ball of towbar must be always kept clear and conserve with a grease.

Towbar accessories:

Pos. 1	Name: Main bar Quantity: 1	Pos. 5	Name: Truncated washer Quantity: 2 Dim.: $\emptyset 58 \times \emptyset 13 \times 5 \text{ mm}$	Pos. 10	Name: Nut 8 B Quantity: 8 Dim.: M12
					
Pos. 2	Name: Tow ball Quantity: 1	Pos. 6	Name: Distance sleeve Quantity: 2 Dim.: $\emptyset 25 \times \emptyset 13 \times 6 \text{ mm}$	Pos. 11	Name: Plain washer Quantity: 8 Dim.: $\emptyset 13 \text{ mm}$
					
Pos. 3	Name: Socket plate Quantity: 1	Pos. 7	Name: Bolt 8,8 B Quantity: 2 Dim.: M12x60 mm	Pos. 12	Name: Spring washer Quantity: 8 Dim.: $\emptyset 12,2 \text{ mm}$
					
Pos. 4	Name: Square washer Quantity: 2	Pos. 8	Name: Bolt 8,8 B Quantity: 2 Dim.: M12x50 mm	Pos. 10	Name: Bolt 8,8 B Quantity: 4 Dim.: M12x30 mm
					



PPUH AUTO-HAK Sp.J.

Produkcja Zaczepów Kulowych
Henryk i Zbigniew Nejman
76-200 SŁUPSK ul. Słoneczna 16K
tel/fax (059) 8-414-414; 8-414-413
e-mail: office@autohak.com.pl
www.autohak.com.pl

Towing hitch (without electrical set)

Class: **A50-X** Cat. no. **V36A**

Designed for:

Manufacturer: **NISSAN**

Model: **SUNNY Traveller**

Type: **ESTATE (Y10), except 4x4**

produced since 04.1991 till 12.2000

Technical data:

D-value: 8,0 kN

maximum trailer weight: **1600 kg**

maximum vertical cup mass: **75 kg**

Approval number according to Directive 94/20/EC: **e20*94/20*0639*00**

Foreword

This towbar is designed according to rules of safety traffic regulations. The towing hitch is a safety component and can be install only by qualified personnel. Any alteration or conversion of the towing hitch is prohibited and would lead to cancellation of design certification. Remove insulating compound and underseal from vehicle (if present) in the area of the matting surfaces of the towing hitch. The vehicle manufacturer's specifications regarding trailer load and max. vertical cup load are decisive for driving whereat values for the towing hitch cannot be exceeded.

D-value formula:

$$\frac{\text{Max trailer weight [kg]} \times \text{Max vehicle weight [kg]}}{\text{Max trailer weight [kg]} + \text{Max vehicle weight [kg]}} \times \frac{9,81}{1000} = D \text{ [kN]}$$