

FITTING INSTRUCTION

Clamp mark in acc. with		Cables joining
ISO	PN	
1	L	Left directional lights
2	+	Rear fog lights
3	31	Ground
4	R	Right directional lights
5	58R	Right side parking lights
6	54	Stoptlights
7	58L	Left side parking lights

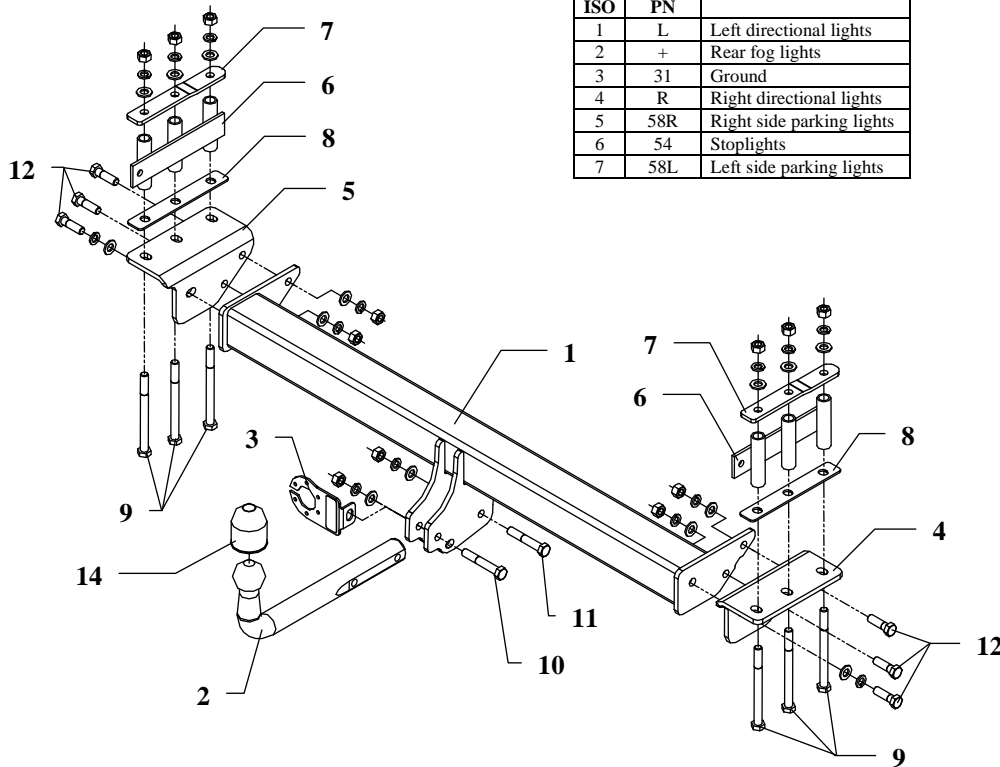

This towbar is designed to assembly in following cars:
NISSAN PATROL 3/5 door (Y61), produced since 01.1998 till 09.2004,
 catalogue no. **V02** and is prepared to tow trailers max total weight up to
3500 kg and max vertical mass **140 kg**.

From manufacturer

Thank you for buying our product. Their reliability has been confirmed in many tests. Reliability of towbar depends also on correct assembly and right operation. For this reasons we kindly ask to read carefully this instruction and apply to hints.

The towbar should be install in points described by a car producer.

The instruction of the assembly

1. Disassemble side parts of the bumper. (it is not necessary to disassemble central panel of the bumper).
2. Fish-plates (pos. 7 and 8), sleeves unit (pos. 6) and side brackets (pos. 4 and 5) fix loosely by four bolts M12x140mm (pos. 9) as shown on the drawing – through original holes.
3. The main bar of the towbar (pos. 1) slip between installed side brackets and fix by bolts M12x35mm (pos. 12) from equipment.
4. Missed holes (see brackets 4 and 5) drill straight through using bit $\varnothing 12,5\text{mm}$ and next fix with bolts M12x140mm (pos. 9).
5. Tighten all bolts according to the torque shown in the table.
6. Fix tow-ball (pos. 2) and socket plate (pos. 3) using bolts M12x75mm (pos. 10) and M12x70mm (pos. 11) from equipment.
7. Connect electric wires of 7-poles socket according to the instruction of the car. (Recommend to make at authorized service station).
8. Complete paint layer damaged during installation.

Torque settings for nuts and bolts (8,8):	
M 8 - 25 Nm	M 10 - 55 Nm
M 12 - 85 Nm	M 14 - 135 Nm



NOTE

After install the towbar you should get adequate note in registration book (at authorised service station). The car should be equipped with:

- Indicators
- Tow mirrors

After 1000km check all bolts and nuts. The ball of towbar must be always kept clear and conserve with a grease.

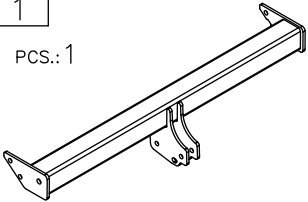
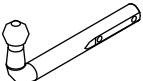
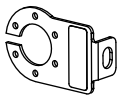
Towbar equipment:

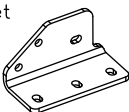
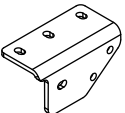
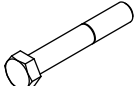
Pos. 1 Main bar PCS.: 1	Pos. 6 Sleeve unit pcs.: 2	Pos. 12 Bolt 8,8 B M12x35mm PCS.: 6
	Pos. 7 Fish-plate 1 pcs.: 2	Pos. 13 Plain washer ø13mm PCS.: 14
Pos. 2 Tow ball PCS.: 1	Pos. 8 Fish-plate 2 pcs.: 2	Pos. 14 Spring washer ø12,2mm PCS.: 14
	Pos. 9 Bolt 8,8 B M12x140mm PCS.: 6	Pos. 15 Nut 8 B M12 PCS.: 12
Pos. 3 Socket plate PCS.: 1	Pos. 10 Bolt 8,8 B M12x75mm PCS.: 1	Pos. 16 Ball cover PCS.: 1
	Pos. 4 Right bracket PCS.: 1	
	Pos. 5 Left bracket PCS.: 1	
	Pos. 11 Bolt 8,8 B M12x70mm PCS.: 1	
		



PPUH AUTO-HAK S.J.

Produkcja Haków Holowniczych
Henryk i Zbigniew Nejman
76-200 SŁUPSK ul. Słoneczna 16K
tel/fax (059) 8-414-414; 8-414-413
Email: office@autohak.com.pl
www.autohak.com.pl

Towing hitch (without electrical set)

Class: **A50-X** Cat. no. **V02**

Designed for:

Manufacturer: **NISSAN**

Model: **PATROL**

Type: **Y61, 3/5 doors**

produced since 01.1998 till 09.2004

Technical data:

D-value: 16,63 kN

maximum trailer weight: **3500 kg**

maximum vertical cup load: **140 kg**

Approval number according to Directive 94/20/EC: e20*94/20*0223*00

Foreword

This towbar is designed according to rules of safety traffic regulations. The towing hitch is a safety component and can be install only by qualified personnel. Any alteration or conversion of the towing hitch is prohibited and would lead to cancellation of design certification. Remove insulating compound and underseal from vehicle (if present) in the area of the matting surfaces of the towing hitch.

The vehicle manufacturer's specifications regarding trailer load and max. vertical cup load are decisive for driving whereat values for the towing hitch cannot be exceeded.

D-value formula:

$$\frac{\text{Max trailer weight [kg]} \times \text{Max vehicle weight [kg]}}{\text{Max trailer weight [kg]} + \text{Max vehicle weight [kg]}} \times \frac{9,81}{1000} = D \text{ [kN]}$$