

FITTING INSTRUCTION

Clamp mark in acc. with		Cables joining
ISO	PN	
1	L	Left directional lights
2	+	Rear fog lights
3	31	Ground
4	R	Right directional lights
5	58R	Right side parking lights
6	54	Stoplights
7	58L	Left side parking lights

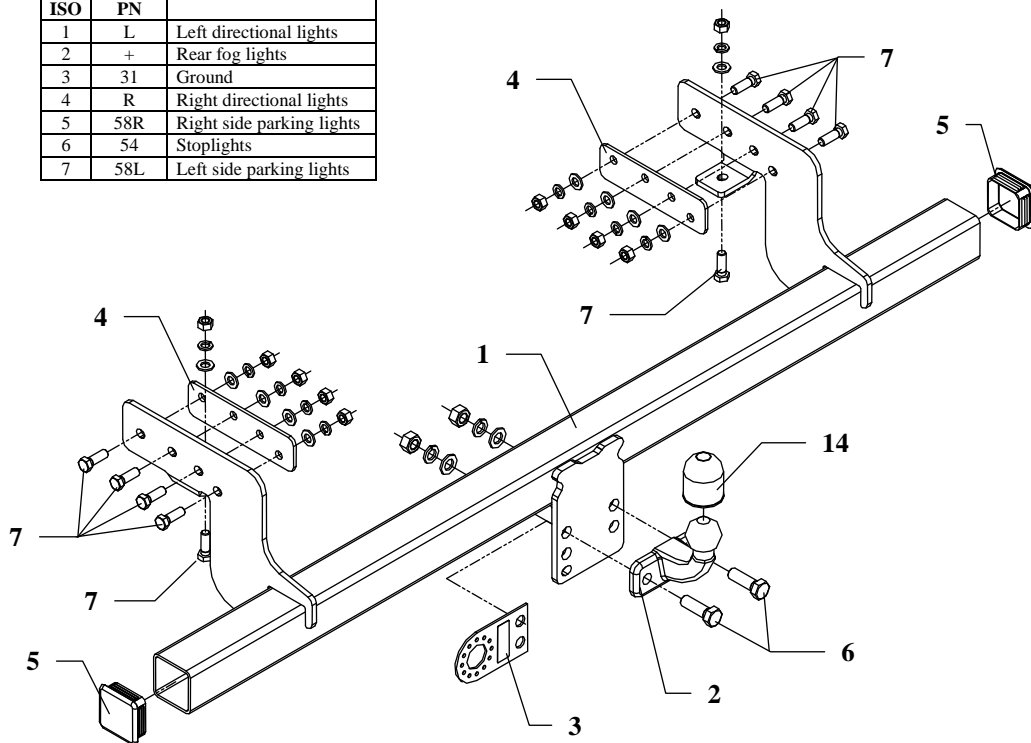

This towing hitch is designed to assembly in following cars:
MITSUBISHI L200, Pick-up (K60T), produced since 10.1996 till 2002 and since 2033 till 04.2006, catalogue number **Z01** and is prepared to tow trailers max total weight up to **2700 kg** and max vertical mass **100 kg**.

From manufacturer

Thank you for buying our product. Their reliability has been confirmed in many tests. Reliability of towing hitch depends also on correct assembly and right operation. For this reasons we kindly ask to read carefully this instruction and apply to hints.

The towing hitch should be installed in points described by a car producer.

The instruction of the assembly

1. Disassemble original bumper-pipe from frame of the car chassis.
2. To place after original bumper-pipe put main bar of the towbar (pos. 1) and fix it through holes in side brackets using bolts M12x35mm (pos. 7) from equipment. From inside of the frame put fish-plates (pos. 4) as shown in the drawing.
3. On ends of pipe put in supplied plugs (pos. 5).
4. Fix tow-ball (pos. 2) with socket plate (pos. 3) using bolts M16x50mm (pos. 6) as shown in the drawing.
5. Tighten all bolts according to the torque shown in the table.
6. Connect electric wires of 7-poles socket according to the instruction of the car. (Recommend to make at authorized service station).
7. Complete paint layer damaged during installation.

Torque settings for nuts and bolts (8,8):

M6 - 11 Nm	M8 - 25 Nm	M10 - 50 Nm
M12 - 87 Nm	M14 - 138 Nm	M16 - 210 Nm









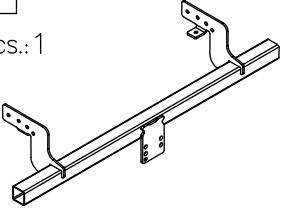
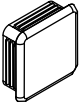

NOTE

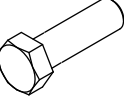
After installation of the towing hitch you should get adequate note in registration book (at authorised service station).The car should be equipped with:

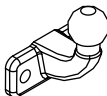
- Indicators
- Tow mirrors

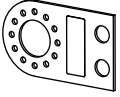
Check all bolts and nuts after **1000 km** of exploitation. The ball of the towing hitch must be always kept clear and conserve with a grease.

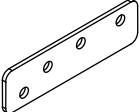
Part list:

Pos. 1 Main bar PCS.: 1 	Pos. 5 Pipe plug PCS.: 2 	Pos. 10 Spring washer Ø16,3mm PCS.: 2 
	Pos. 6 Bolt 8,8 B M16x50mm PCS.: 2 	Pos. 11 Spring washer Ø12,2mm PCS.: 10 
Pos. 2 Tow ball PCS.: 1 	Pos. 7 Bolt 8,8 B M12x35mm PCS.: 10 	Pos. 12 Nut 8 B M16 PCS.: 2 
Pos. 3 Socket plate PCS.: 1 	Pos. 8 Plain washer Ø17mm PCS.: 2 	Pos. 13 Nut 8 B M12 PCS.: 10 
Pos. 4 Fish-plate PCS.: 2 	Pos. 9 Plain washer Ø13mm PCS.: 10 	Pos. 14 Ball cover PCS.: 1 



PPUH AUTO-HAK S.J.

Produkcja Haków Holowniczych
Henryk & Zbigniew Nejman
76-200 SŁUPSK ul. Słoneczna 16K
tel/fax (059) 8-414-414; 8-414-413
E-mail: office@autohak.com.pl
www.autohak.com.pl

Towing hitch (without electrical set)

Class: **A50-X** Cat. no. **Z01**

Designed for:

Manufacturer: **mitsubishi**

Model: **L-200**

Type: **Pick-up (60T)**

produced since 10.1996 till 2002 and since 2033 till 04.2006

Technical data:

D-value: 13,8 kN

maximum trailer weight: **2700 kg**

maximum vertical cup mass: **100 kg**

Approval number according to Directive 94/20/EC: e20*94/20*0518*00

Foreword

This towing hitch is designed according to rules of safety traffic regulations. The towing hitch is a safety component and can be install only by qualified personnel. Any alteration or conversion of the towing hitch is prohibited and would lead to cancellation of design certification. Remove insulating compound and underseal from vehicle (if present) in the areas of the matting surfaces of the towing hitch. The vehicle manufacturer's specifications regarding trailer load and max. vertical cup mass are decisive for driving whereat values for the towing hitch cannot be exceeded.

D-value formula:

$$\frac{\text{Max trailer weight [kg]} \times \text{Max vehicle weight [kg]}}{\text{Max trailer weight [kg]} + \text{Max vehicle weight [kg]}} \times \frac{9,81}{1000} = D \text{ [kN]}$$