

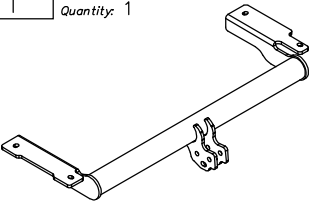

## Towing hitch accessories:

Pos. 1 Name: Main bar Quantity: 1	Pos. 5 Name: Distance sleeve Quantity: 4	Pos. 10 Name: Plain washer Quantity: 2 Dim.: Ø 13 mm
	Pos. 6 Name: Bolt 8,8 B Quantity: 2 Dim.: M12x75mm	Pos. 11 Name: Plain washer Quantity: 4 Dim.: Ø 10,5 mm
Pos. 2 Name: Tow ball Quantity: 1	Pos. 7 Name: Bolt 8,8 B Quantity: 4 Dim.: M10x90mm	Pos. 12 Name: Spring washer Quantity: 2 Dim.: Ø 12,2 mm
	Pos. 8 Name: Nut 8 B Quantity: 2 Dim.: M12	Pos. 13 Name: Spring washer Quantity: 4 Dim.: Ø 10,2 mm
Pos. 3 Name: Socket plate Quantity: 1	Pos. 9 Name: Nut 8 B Quantity: 4 Dim.: M10	Pos. 14 Name: Ball cover Quantity: 1
		
Pos. 4 Name: Fish-plate Quantity: 2		
		

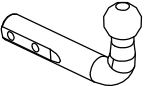
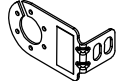

**PPUH AUTO-HAK Sp.J.**

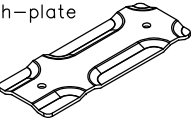
Produkcja Zaczepów Kulowych  
Henryk & Zbigniew Nejman  
76-200 SŁUPSK ul. Słoneczna 16K  
tel/fax (059) 8-414-414; 8-414-413  
E-mail: [office@autohak.com.pl](mailto:office@autohak.com.pl)  
[www.autohak.com.pl](http://www.autohak.com.pl)

## Towing hitch (without electrical set)

Class: **A50-X** Cat. no. **H04**

Designed for:

Manufacturer: **SKODA**

Model: **FAVORIT FORMAN**

Type: **ESTATE**

produced since 01.1991 till 12.1995

Technical data:

**D-value: 5,9 kN**

maximum trailer weight: **900 kg**

maximum vertical cup load: **50 kg**

**Approval number according to Directive 94/20/EC: e20\*94/20\*1344\*00**

## Foreword

This towing hitch is designed according to rules of safety traffic regulations. The towing hitch is a safety component and can be installed only by qualified personnel. Any alteration or conversion of the towing hitch is prohibited and would lead to cancellation of design certification. Remove insulating compound and underseal from vehicle (if present) in the area of the mating surfaces of the towing hitch.

The vehicle manufacturer's specifications regarding trailer mass and max. vertical cup mass are decisive for driving whereat values for the towing hitch cannot be exceeded.

*D-value formula:*

$$\frac{\text{Max trailer weight [kg]} \times \text{Max vehicle weight [kg]}}{\text{Max trailer weight [kg]} + \text{Max vehicle weight [kg]}} \times \frac{9,81}{1000} = D \text{ [kN]}$$

## FITTING INSTRUCTION

Clamp mark in acc. with		Cables joining
ISO	PN	
1	L	Left directional lights
2	+	Rear fog lights
3	31	Ground
4	R	Right directional lights
5	58R	Right side parking lights
6	54	Stoplights
7	58L	Left side parking lights

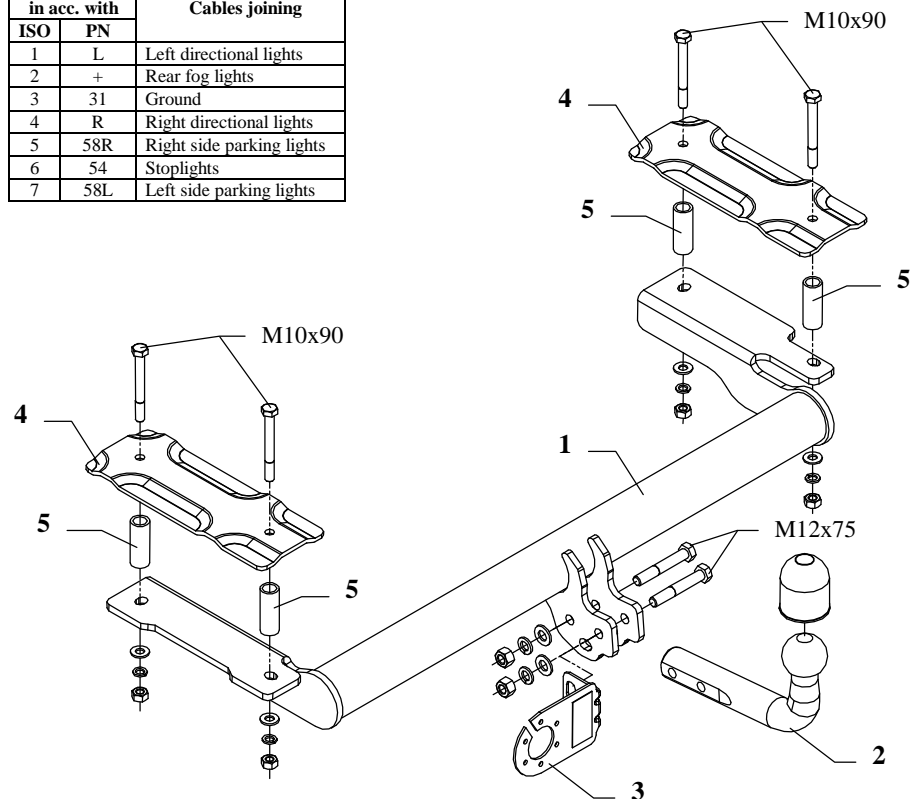

This towing hitch is designed to assembly in following cars: **SKODA FAVORIT FORMAN, ESTATE**, produced since 01.1991 till 12.1995 catalogue no. **H04** and is prepared to tow trailers max total weight **900 kg** and max vertical load **50 kg**.

### *From manufacturer*

Thank you for buying our product. Their reliability has been confirmed in many tests. Reliability of towbar depends also on correct assembly and right operation. For this reasons we kindly ask to read carefully this instruction and apply to hints.

*The towbar should be install in points described by a car producer.*

## The instruction of the assembly

1. Find factory marked points (on the left and right side in the trunk) and drill holes using bit  $\varnothing 22\text{mm}$ .
2. To maked holes slip distance sleeves  $L=56\text{mm}$  (pos. 5) and put fish-plates (pos. 4), next insert bolts  $M10 \times 90\text{mm}$  (pos. 7), see drawing.
3. From the bottom of the car, on protruding bolts, put the main bar of the towbar (pos. 1) and fix with right torque from the table.
4. Fix tow-ball (pos. 2) and socket plate (pos. 3) using bolts  $M12 \times 75\text{mm}$  (pos. 6) from accessories.
5. Tighten all bolts according to the torque shown in the table.
6. Connect electric wires of 7-poles socket according to the instruction of the car. (Recommend to make at authorized service station).
7. Complete paint layer damaged during installation.

Torque settings for nuts and bolts (8,8):

<b>M6</b> - 11 Nm	<b>M8</b> - 25 Nm	<b>M10</b> - 50 Nm
<b>M12</b> - 87 Nm	<b>M14</b> - 138 Nm	<b>M16</b> - 210 Nm

## NOTE

After install the towbar you should get adequate note in registration book (at authorised service station).The car should be equipped with:

- Indicators
- Tow mirrors

After 1000km of exploitation check all bolts and nuts. The ball of towbar must be always kept clear and conserve with a grease.