

## FITTING INSTRUCTION

Clamp mark in acc. with		Cables joining
ISO	PN	
1	L	Left directional lights
2	+	Rear fog lights
3	31	Ground
4	R	Right directional lights
5	58R	Right side parking lights
6	54	Stoplights
7	58L	Left side parking lights

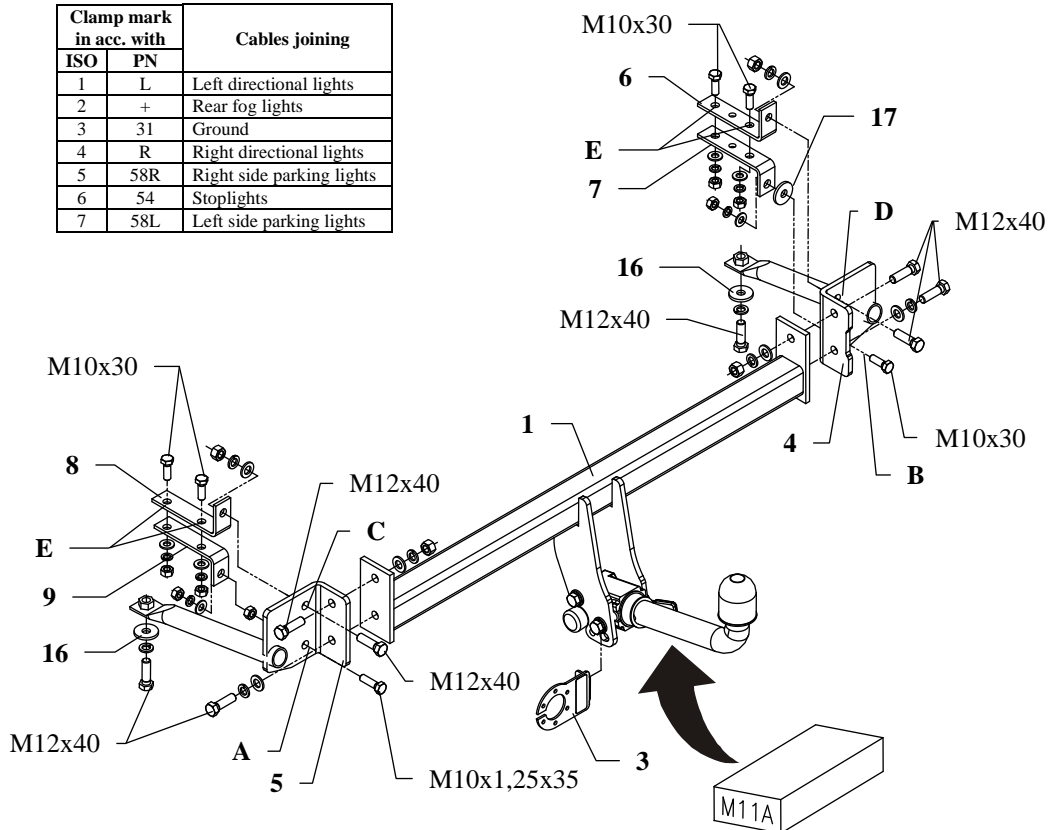

This towbar is designed to assembly in following cars:  
**MAZDA 626, 4/5 doors (GE)**, produced since 08.1991 till 06.1997, catalogue number **M11A** and is prepared to tow trailers max total weight **1700 kg** and max vertical mass **70 kg**.

### *From manufacturer*

Thank you for buying our product. Their reliability has been confirmed in many tests. Reliability of towbar depends also on correct assembly and right operation. For this reasons we kindly ask to read carefully this instruction and apply to hints.

*The towbar should be install in points described by a car producer.*

## The instruction of the assembly

1. Disassemble rear panel, rear bumper and original tow eye (tow eye not used any more).
2. Put templates to rear wall of the body as shown on the figure 2. Mark points "X" and drill it using bit  $\varnothing 40\text{mm}$ .
3. To made holes put side brackets (pos. 4 and 5) as shown on the figure. Through original holes underneath the car fix it loosely using bolts M12x40mm (pos. 10) as shown on the figure, use big washers (pos. 16).
4. On the right side, inside the trunk to rear wall put handle I (pos. 6) and fix using bolt M12x40mm (pos. 10) with right bracket (pos. 4) through hole D.
5. On the let side, inside the trunk to rear wall put handle III (pos. 8) and fix using bolt M12x40mm (pos. 10) with left bracket (pos. 5) through hole C.
6. On the left side of the car, through hole A in the left bracket (pos. 5) and welded nut twist on bolt M10x1,25x35mm (pos. 11) and next on his protruding, threaded part put handle IV (pos. 9) and fix by nut M10x1,25 (pos. 14) as shown on the figure.  
**NOTE!** In models since 06.1994 there is no welded nut in rear wall of the car. Because of that is necessary to put bolt and twist on nut M10x1,25 and then fix handle IV (pos. 9) as described above.
7. On the right side of the car, through hole pos. B in right bracket (pos. 4) put bolt M10x30mm (pos. 12), big washer  $\varnothing 35 \times \varnothing 12 \times 3$  (pos. 16) and next fix handle III (pos. 7).
8. Through holes (pos. E) drill holes  $\varnothing 1\text{mm}$  and next fix together handles using bolts M10x30mm (pos. 12). **Note!** During torsion of handles pos. 6 and 7 or pos. 8 and 9 floor of the trunk can be flatted.
9. Between mounted side brackets put main bar of the towbar (pos. 1) and fix it using bolts M12x40mm (pos. 10).
10. Reassemble bumper and rear panel.
11. Fix body of the automat and place tow-ball according to supplied instruction. Note! Remember to place socket plate (pos. 3) as shown on the drawing 1.
12. Connect electric wires of 7-poles socket according to the instruction of the car. (Recommend to make at authorized service station)
13. Complete paint layer damaged during installation.

Torque settings for nuts and bolts (8,8):	
<b>M 8</b> - 25 Nm	<b>M 10</b> - 55 Nm
<b>M 12</b> - 85 Nm	<b>M 14</b> - 135 Nm



### NOTE

After install the towbar you should get adequate note in registration book (at authorised service station).The car should be equipped with:

- Indicators
- Tow mirrors

After 1000km of exploitation check all bolts and nuts. The ball of towbar must be always kept clear and conserve with a grease.

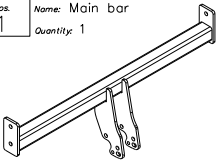
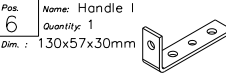
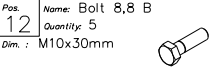
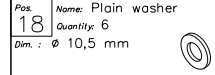
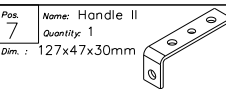
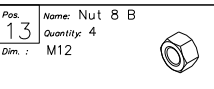
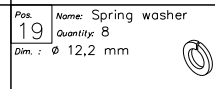
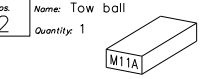
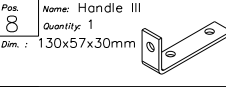
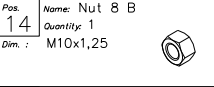
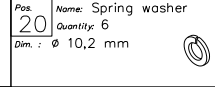
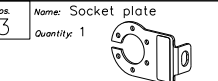
## Towbar equipment:

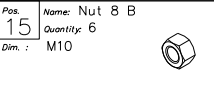
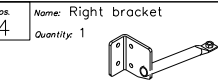
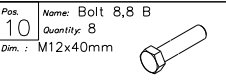
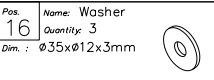
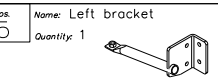
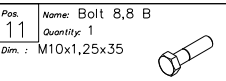
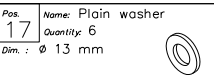
Pos. 1 Name: Main bar Quantity: 1 	Pos. 6 Name: Handle I Quantity: 1 Dim.: 130x57x30mm 	Pos. 12 Name: Bolt 8,8 B Quantity: 5 Dim.: M10x30mm 	Pos. 18 Name: Plain washer Quantity: 6 Dim.: Ø 10,5 mm 
	Pos. 7 Name: Handle II Quantity: 1 Dim.: 127x47x30mm 	Pos. 13 Name: Nut 8 B Quantity: 4 Dim.: M12 	Pos. 19 Name: Spring washer Quantity: 8 Dim.: Ø 12,2 mm 
Pos. 2 Name: Tow ball Quantity: 1 	Pos. 8 Name: Handle III Quantity: 1 Dim.: 130x57x30mm 	Pos. 14 Name: Nut 8 B Quantity: 1 Dim.: M10x1,25 	Pos. 20 Name: Spring washer Quantity: 6 Dim.: Ø 10,2 mm 
Pos. 3 Name: Socket plate Quantity: 1 	Pos. 9 Name: Handle IV Quantity: 1 Dim.: 121x47x30mm 	Pos. 15 Name: Nut 8 B Quantity: 6 Dim.: M10 	
Pos. 4 Name: Right bracket Quantity: 1 	Pos. 10 Name: Bolt 8,8 B Quantity: 8 Dim.: M12x40mm 	Pos. 16 Name: Washer Quantity: 3 Dim.: Ø35xØ12x3mm 	
Pos. 5 Name: Left bracket Quantity: 1 	Pos. 11 Name: Bolt 8,8 B Quantity: 1 Dim.: M10x1,25x35 	Pos. 17 Name: Plain washer Quantity: 6 Dim.: Ø 13 mm 	



**PPUH AUTO-HAK S.J.**

Produkcja Zaczepów Kulowych  
Henryk i Zbigniew Nejman  
76-200 SŁUPSK ul. Słoneczna 16K  
tel/fax (059) 8-414-414; 8-414-413  
E-mail: [office@autohak.com.pl](mailto:office@autohak.com.pl)  
[www.autohak.com.pl](http://www.autohak.com.pl)

## Towing hitch (without electrical set)

Class: **A50-X** Cat. no. **M11A**

Designed for:

Manufacturer: **MAZDA**

Model: **626**

Type: **4/5 doors (GE)**

produced since 08.1991 till 06.1997

Technical data:

**D-value: 9,1 kN**

maximum trailer weight: **1700 kg**

maximum vertical cup mass: **70 kg**

**Approval number according to Directive 94/20/EC: e20\*94/20\*0599\*00**

## Foreword

This towbar is designed according to rules of safety traffic regulations. The towing hitch is a safety component and can be install only by qualified personnel. Any alteration or conversion of the towing hitch is prohibited and would lead to cancellation of design certification. Remove insulating compound and underseal from vehicle (if present) in the area of the matting surfaces of the towing hitch.

The vehicle manufacturer's specifications regarding trailer load and max. vertical cup load are decisive for driving whereat values for the towing hitch cannot be exceeded.

*D-value formula:*

$$\frac{\text{Max trailer weight [kg]} \times \text{Max vehicle weight [kg]}}{\text{Max trailer weight [kg]} + \text{Max vehicle weight [kg]}} \times \frac{9,81}{1000} = D \text{ [kN]}$$