

PPUH AUTO-HAK Sp.J.

Henryk & Zbigniew Nejman
ul. Słoneczna 16K 76-200 SŁUPSK
POLAND

tel/fax +48 059 8-414-414; 8-414-413

e-mail: office@autohak.com.pl

www.autohak.com.pl



AUTO-HAK



**DACIA SANDERO
STEPWAY 5D**

Cat. no:

G61A



2009 → 12.2012

e20

e20*94/20*1182*00



1,5h

D

7,3 kN



R=1350 kg



-



S=75 kg



-

20,6 kg

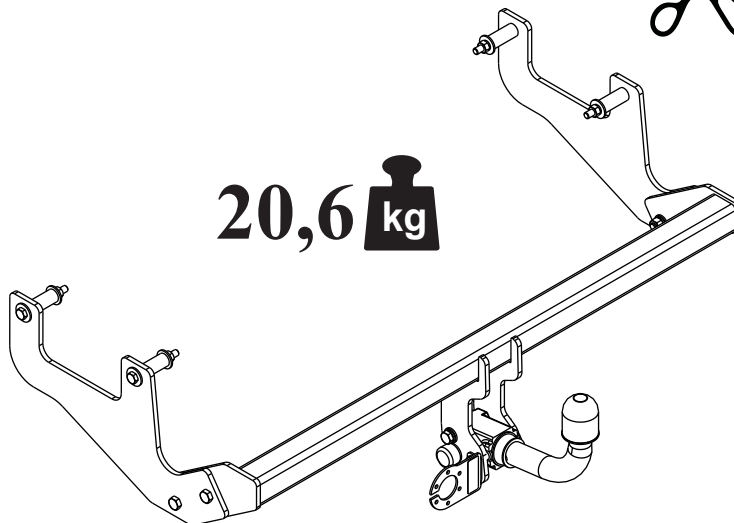

M6 - 11 Nm
M10 - 50 Nm
M14 - 138 Nm

M8 - 25 Nm
M12 - 87 Nm
M16 - 210 Nm



0 km →



1000 km