

## Towing hitch accessories:

Pos. 1 Main bar PCS.: 1	Pos. 6 Fish-plate I PCS.: 2	Pos. 12 Bolt 8,8 B M12x1.25x40mm PCS.: 8
	Pos. 7 Fish-plate II PCS.: 2	Pos. 13 Bolt 8,8 B M12x35mm PCS.: 2
Pos. 2 Tow ball PCS.: 1	Pos. 8 Distance sleeve ø25x4mm L=8mm PCS.: 2	Pos. 14 Nut 8 B M12 PCS.: 4
Pos. 3 Socket plate PCS.: 1	Pos. 9 Bolt 8,8 B M12x75mm PCS.: 1	Pos. 15 Plain washer ø13mm PCS.: 14
Pos. 4 Right bracket PCS.: 1	Pos. 10 Bolt 8,8 B M12x70mm PCS.: 1	Pos. 16 Spring washer ø12,2mm PCS.: 14
Pos. 5 Left bracket PCS.: 1	Pos. 11 Bolt 8,8 B M12x50mm PCS.: 2	Pos. 17 Ball cover PCS.: 1



## PPUH AUTO-HAK Sp.J.

Produkcja Zaczepów Kulowych  
Henryk & Zbigniew Nejman  
76-200 SŁUPSK ul. Słoneczna 16K  
tel/fax (059) 8-414-414; 8-414-413  
E-mail: [office@autohak.com.pl](mailto:office@autohak.com.pl)  
[www.autohak.com.pl](http://www.autohak.com.pl)

## Towing hitch (without electrical set)

Class: **A50-X** Cat. no. **Z26**

Designed for:

Manufacturer: **mitsubishi**

Model: **PININ**

Type: **5 doors (H70)**

produced since 08.2000 till 06.2007

Technical data:

**D-value: 8,1 kN**

maximum trailer weight: **1500 kg**

maximum vertical cup mass: **75 kg**

**Approval number acc. to regulations EKG/ONZ 55.01: E20-55R-01 0915**

## Foreword

This towing hitch is designed according to rules of safety traffic regulations. The towing hitch is a safety component and can be installed only by qualified personnel. Any alteration or conversion of the towing hitch is prohibited and would lead to cancellation of design certification. Remove insulating compound and underseal from vehicle (if present) in the area of the mating surfaces of the towing hitch. The vehicle manufacturer's specifications regarding trailer mass and max. vertical cup mass are decisive for driving whereat values for the towing hitch cannot be exceeded.

*D-value formula:*

$$\frac{\text{Max trailer weight [kg]} \times \text{Max vehicle weight [kg]}}{\text{Max trailer weight [kg]} + \text{Max vehicle weight [kg]}} \times \frac{9,81}{1000} = D \text{ [kN]}$$

## FITTING INSTRUCTION

Clamp mark in acc. with		Cables joining
ISO	PN	
1	L	Left directional lights
2	+	Rear fog lights
3	31	Ground
4	R	Right directional lights
5	58R	Right side parking lights
6	54	Stoplights
7	58L	Left side parking lights

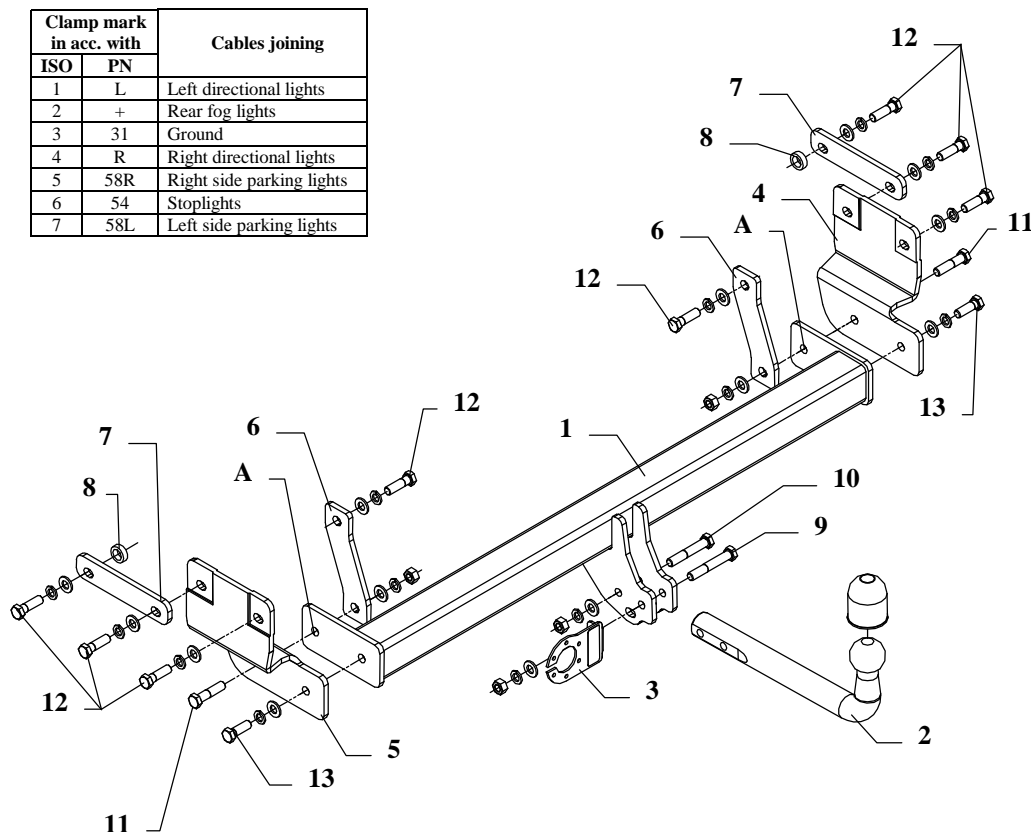

This towing hitch is designed to assembly in following cars:  
**MITSUBISHI PININ, 5 doors (H70)**, produced since 08.2000 till 06.2007, catalogue no. **Z26** and is prepared to tow trailers max total weight **1500 kg** and max vertical mass **75 kg**.

### *From manufacturer*

Thank you for buying our product. Their reliability has been confirmed in many tests. Reliability of towing hitch depends also on correct assembly and right operation. For this reasons we kindly ask to read carefully this instruction and apply to hints.

*The towing hitch should be install in points described by a car producer.*

## The instruction of the assembly

1. Unscrew bolts of the towing eye from the left chassis member, then fix loosely bracket (pos. 5) and fish-plate (pos. 7) using bolts M12x1.25x40mm (pos. 12). Place distance sleeve (pos. 8) as showed on the drawing.
2. Fix loosely bracket (pos. 4) and fish-plate (pos. 7) to the right chassis member using bolts M12x1.25x40mm (pos. 12). Place distance sleeve (pos. 8) as showed on the drawing.
3. Put the main bar of the towing hitch (pos. 1) between brackets (pos. 4 and 5) and fix it using bolts M12 as showed on the drawing.
4. Fix fish-plates (pos. 6) to inside the chassis members through holes – pos. A (see the drawing).
5. Fix tow-ball (pos. 2) with socket plate (pos. 3) using bolts M12x75mm (pos. 9) and M12x70mm (pos. 10) from accessories.
6. Tighten all bolts according to the torque shown in the table.
7. Connect electric wires of 7-poles socket according to the instruction of the car. (Recommend to make at authorized service station).
8. Complete paint layer damaged during installation.

Torque settings for nuts and bolts (8,8):

<b>M6</b> - 11 Nm	<b>M 8</b> - 25 Nm	<b>M 10</b> - 50 Nm
<b>M 12</b> - 87 Nm	<b>M 14</b> - 138 Nm	<b>M16</b> - 210 Nm

### NOTE

After installation of a towing hitch you should get adequate note in registration book (at authorised service station). The car should be equipped with:

- Indicators
- Tow mirrors

After 1000km of exploitation check all bolts and nuts. The ball of towing hitch must be always kept clear and conserve with a grease.