

FITTING INSTRUCTION

Clamp mark in acc. with		Cables joining
ISO	PN	
1	L	Left directional lights
2	+	Rear fog lights
3	31	Ground
4	R	Right directional lights
5	58R	Right side parking lights
6	54	Stoplights
7	58L	Left side parking lights

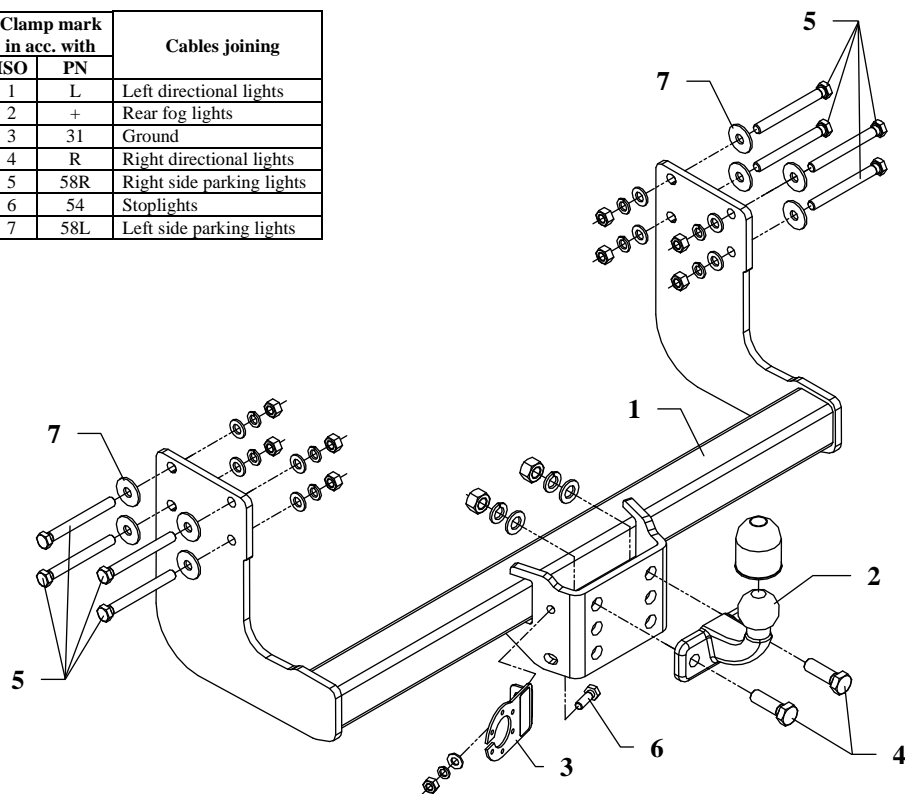

This towbar is designed to assembly in following cars:
MERCEDES SPRINTER / VOLKSWAGEN CRAFTER, 3,665/4,325m, metal built-up and loading platform, without step board, single wheels and MERCEDES SPRINTER 5.0t, / VOLKSWAGEN CRAFTER 5.0t 3,665/4,325m, metal built-up and loading platform, without step board, double wheels, all produced since 04.2006, catalogue no. D35 and is prepared to tow trailers max total weight **3500 kg** and max vertical load **150 kg**.

From manufacturer

Thank you for buying our product. Their reliability has been confirmed in many tests. Reliability of towbar depends also on correct assembly and right operation. For this reasons we kindly ask to read carefully this instruction and apply to hints.

The towbar should be install in points described by a car producer.

The instruction of the assembly

1. For the purpose of installing of the towbar one ought to disassemble the factory towing eye, which is fixed on the internal side of the frame.
 2. Slip the main bar of the towbar (pos. 1) between frame and fix using bolts M12x110mm (pos. 5) from the towbar accessories.
- ATTENTION!** Apply the original towing eye on the internal side of the frame and fix together with towbar.
3. Fix tow-ball (pos. 2) using bolts M16x50mm (pos. 4) from accessories.
 4. Fix the socket plate (pos. 3) using bolt M10x30mm (pos. 6) as shown on the drawing.
 5. Tighten all bolts according to the torque shown in the table.
 6. Connect electric wires of 7-poles socket according to the instruction of the car. (Recommend to make at authorized service station).
 7. Complete paint layer damaged during installation.

Torque settings for nuts and bolts (8,8):

M6 - 11 Nm	M8 - 25 Nm	M10 - 50 Nm
M12 - 87 Nm	M14 - 138 Nm	M16 - 210 Nm

NOTE











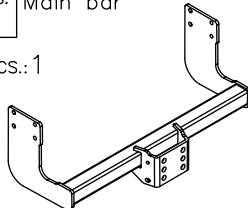

After install the towbar you should get adequate note in registration book (at authorised service station).The car should be equipped with:

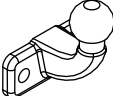
- Indicators
- Tow mirrors

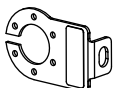
After 1000km of exploitation check all bolts and nuts. The ball of towbar must be always kept clear and conserve with a grease.

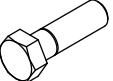

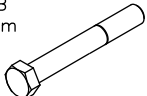
Towbar accessories:

Pos. 1 Main bar PCS.: 1 	Pos. 6 Bolt 8,8 B M10x30mm PCS.: 1 	Pos. 12 Spring washer ø12,2mm PCS.: 8 
	Pos. 7 Plain washer ø37xø13x3mm PCS.: 8 	Pos. 13 Spring washer ø10,2mm PCS.: 1 
Pos. 2 Tow ball PCS.: 1 	Pos. 8 Plain washer ø17mm PCS.: 2 	Pos. 14 Nut 8 B M16 PCS.: 2 
Pos. 3 Socket plate PCS.: 1 	Pos. 9 Plain washer ø13mm PCS.: 8 	Pos. 15 Nut 8 B M12 PCS.: 8 
Pos. 4 Bolt 8,8 B M16x50mm PCS.: 2 	Pos. 10 Plain washer ø10,5mm PCS.: 1 	Pos. 16 Nut 8 B M10 PCS.: 1 
Pos. 5 Bolt 8,8 B M12x110mm PCS.: 8 	Pos. 11 Spring washer ø16,3mm PCS.: 2 	Pos. 17 Ball cover PCS.: 1 

Towing hitch (without electrical set)

Class: **A50-X** Cat. no. **D35**

Designed for:

MERCEDES SPRINTER

VOLKSWAGEN CRAFTER

Type: **3,665/4,325m, metal built-up,
loading platform, without step board,
single wheels**

and

MERCEDES SPRINTER 5.0t

VOLKSWAGEN CRAFTER 5.0t

Type: **3,665/4,325m, metal built-up
without step board, double wheels**

all produced since 04.2006

Technical data:

D-value: 17,2 kN

maximum trailer weight: **3500 kg**

maximum vertical cup load: **150 kg**

Approval number acc. to regulations EKG/ONZ 55.01: E20-55R-01 4169

Foreword

This towbar is designed according to rules of safety traffic regulations. The towing hitch is a safety component and can be install only by qualified personnel. Any alteration or conversion of the towing hitch is prohibited and would lead to cancellation of design certification. Remove insulating compound and underseal from vehicle (if present) in the area of the matting surfaces of the towing hitch.

The vehicle manufacturer's specifications regarding trailer load and max. vertical cup load are decisive for driving whereat values for the towing hitch cannot be exceeded.

D-value formula:

$$\frac{\text{Max trailer weight [kg]} \times \text{Max vehicle weight [kg]}}{\text{Max trailer weight [kg]} + \text{Max vehicle weight [kg]}} \times \frac{9,81}{1000} = D \text{ [kN]}$$