

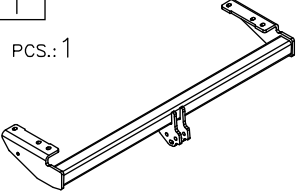

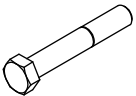



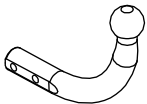

## Towbar accessories:

Pos. 1	Main bar 	Pos. 4	Bolt 8,8 B M12x75mm 	Pos. 8	Nut 8 B M12 
PCS.: 1		PCS.: 2		PCS.: 2	
Pos. 2	Tow ball 	Pos. 5	Bolt 8,8 B M12x40mm 	Pos. 9	Rivet ø4x20mm 
PCS.: 1		PCS.: 6		PCS.: 3	
Pos. 3	Socket plate 	Pos. 6	Plain washer ø13mm 	Pos. 10	Ball cover 
PCS.: 1		PCS.: 8		PCS.: 1	
Pos. 7	Spring washer ø12,2mm 				
PCS.: 8					

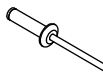
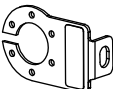

## PPUH AUTO-HAK Sp.J.

Produkcja Zaczepów Kulowych  
Henryk & Zbigniew Nejman  
76-200 SŁUPSK ul. Słoneczna 16K  
tel/fax (059) 8-414-414; 8-414-413  
E-mail: office@autohak.com.pl  
www. autohak.com.pl

## Towing hitch (without electrical set)

Class: **A50-X** Cat. no. **L25**

Designed for:

Manufacturer: **VOLVO**

Model: **XC70**

Type: **ESTATE**

produced since 03.2000 till 08.2007

Technical data:

**D-value: 10,3 kN**

maximum trailer weight: **2000 kg**

maximum vertical cup load: **75 kg**

**Approval number acc. to regulations EKG/ONZ 55.01: E20 55R-01 3373**

## Foreword

This towbar is designed according to rules of safety traffic regulations. The towing hitch is a safety component and can be install only by qualified personnel. Any alteration or conversion of the towing hitch is prohibited and would lead to cancellation of design certification. Remove insulating compound and underseal from vehicle (if present) in the area of the matting surfaces of the towing hitch.

The vehicle manufacturer's specifications regarding trailer load and max. vertical cup load are decisive for driving, and values for the towing hitch cannot be exceeded.

*D-value formula:*

$$\frac{\text{Max trailer weight [kg]} \times \text{Max vehicle weight [kg]}}{\text{Max trailer weight [kg]} + \text{Max vehicle weight [kg]}} \times \frac{9,81}{1000} = D \text{ [kN]}$$

## FITTING INSTRUCTION

Clamp mark in acc. with		Cables joining
ISO	PN	
1	L	Left directional lights
2	+	Rear fog lights
3	31	Ground
4	R	Right directional lights
5	58R	Right side parking lights
6	54	Stoplights
7	58L	Left side parking lights

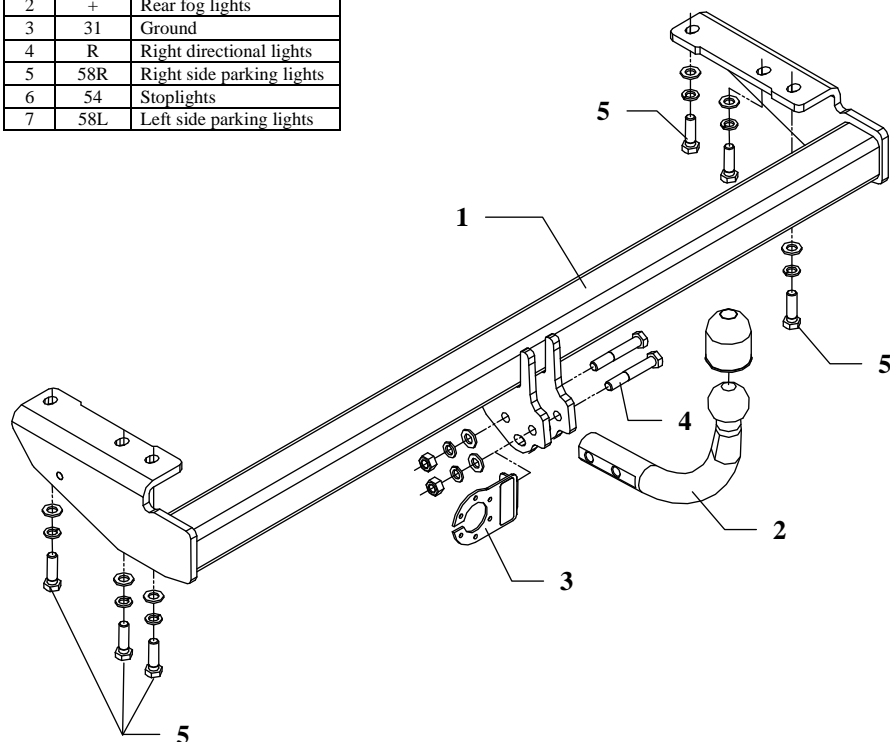

This towbar is designed to assembly in following cars:  
**VOLVO XC70 ESTATE**, produced since 03.2000 till 08.2007, catalogue number **L25** and is prepared to tow trailers max total weight **2000 kg** and max vertical load **75 kg**.

### *From manufacturer*

Thank you for buying our product. Their reliability has been confirmed in many tests. Reliability of towbar depends also on correct assembly and right operation. For this reasons we kindly ask to read carefully this instruction and apply to hints.

*The towbar should be install in points described by a car producer.*

## The instruction of the assembly

1. Disassemble the bumper (drill rivets).
2. Disassemble muffler handle (twist off two bolts and drill pipe rivets from thermal shield).
3. **NOTE!** Muffler handle will be not reinstalled. Thermal shield fix by rivet again.
4. On the right side disassemble original towing eye (not used any more).
5. Put the main bar of the towbar (pos. 1) to chassis members and fix it using bolts M12x40mm (pos. 5) through original holes in members.
6. Reassemble the bumper after cut out fragment according to fig. 2.

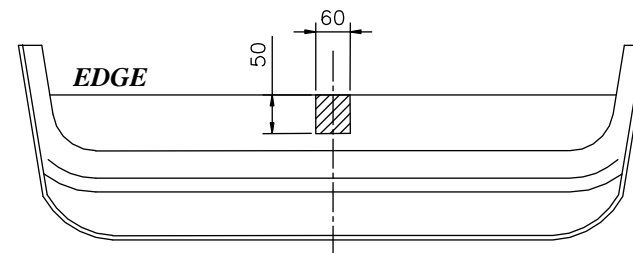

7. Fix tow-ball (pos. 2) and socket plate (pos. 3) by bolts M12x75mm (pos. 4) from accessories.
8. Tighten all bolts according to the torque shown in the table.
9. Connect electric wires of 7-poles socket according to the instruction of the car. (Recommend to make at authorized service station)
10. Complete paint layer damaged during installation.

Torque settings for nuts and bolts (8,8):

<b>M6</b> - 11 Nm	<b>M8</b> - 25 Nm	<b>M10</b> - 50 Nm
<b>M12</b> - 87 Nm	<b>M14</b> - 138 Nm	<b>M16</b> - 210 Nm

### **NOTE**

After install the towbar you should get adequate note in registration book (at authorised service station).The car should be equipped with:

- Indicators
- Tow mirrors

After 1000km of exploitation check all bolts and nuts. The ball of towbar must be always kept clear and conserve with a grease.