

THE GUARANTEE

The producer gives the guarantee with the present guarantee on period 24 months to count since the day of the purchase of this unit:

KH4-1

Produced Purchased.....

The range of the guarantee embraces exclusively qualitative consequential defects from the guilt of the producer.

The guarantee does not embrace instead damages been guilty by the buyer, consequential from the unsuitable assembly, the use or the preservation, damages mechanical, the normal waste during the exploitation etc.

The guarantee given on bought commodity does not switch off, does not limit nor hangs authorizations purchaser consequential from the disagreement of the commodity with the contract.

Complaints one ought to notify in the point of sale, to fold simultaneously the guarantee. The removal "of the defect" succeeds to the ascertainment by the point of sale along with the producer of the rightness composite complaint.

The complaint should be done in the course 14 days since the day of the acknowledgement of the complaint. The guarantee is unimportant unless is full and signed.

The date of the notification of the complaint:



PPUH AUTO-HAK Sp.J.

Produkcja Zaczepów Kulowych
Henryk & Zbigniew Nejman
76-200 SŁUPSK ul. Słoneczna 16K
tel/fax (059) 8-414-414; 8-414-413
E-mail: office@autohak.com.pl
www.autohak.com.pl

Fitting instruction for plate with ball KH4-1

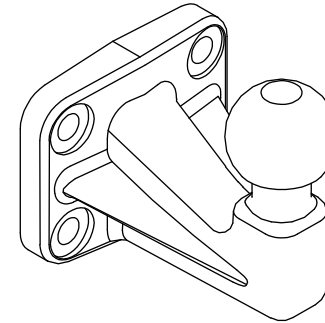

Technical data:

D-value: 23,5 kN

maximum vertical cup mass: **150 kg**

Approval number acc. to regulations EKG/ONZ 55.01: E20-55R-01 3680

Foreword

This plate with ball KH4-1 is designed according to rules of safety traffic regulations. This unit KH4-1 is a safety component and can be install only by qualified personnel. Any alteration or conversion of the towing hitch is prohibited and would lead to cancellation of design certification. Remove insulating compound and underseal from vehicle (if present) in the area of the matting surfaces of the towing hitch.

The vehicle manufacturer's specifications regarding trailer load and max. vertical cup load are decisive for driving, and values for the towing hitch cannot be exceeded.

D-value formula:

$$\frac{\text{Max trailer weight [kg]} \times \text{Max vehicle weight [kg]}}{\text{Max trailer weight [kg]} + \text{Max vehicle weight [kg]}} \times \frac{9,81}{1000} = \mathbf{D [kN]}$$

Fitting instruction for plate with ball KH4-1.

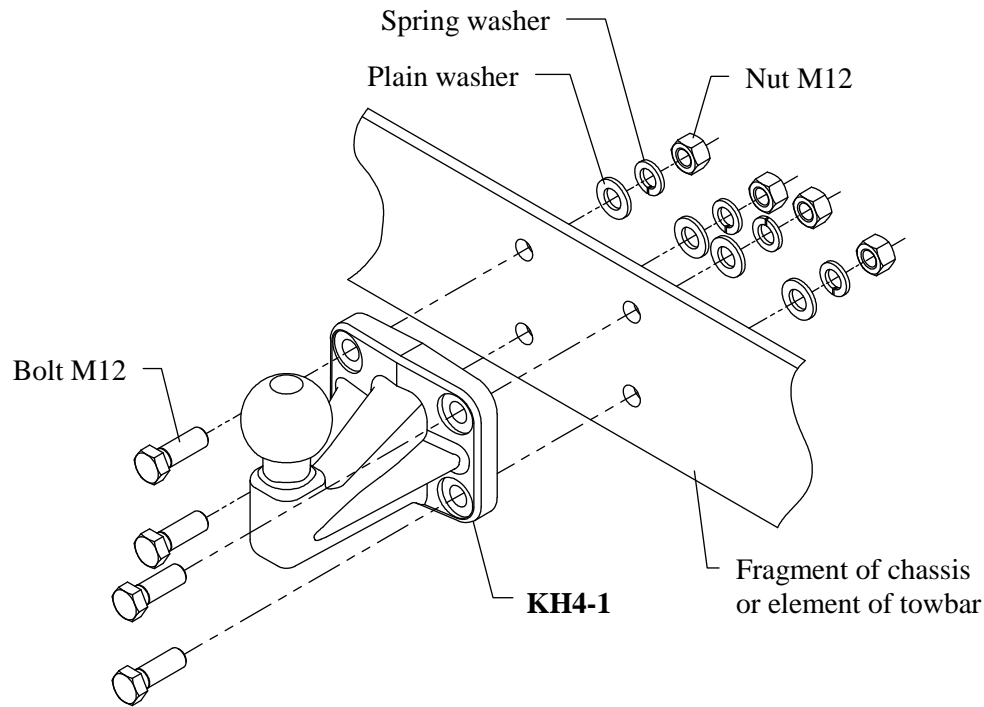

Fig. 1 Hypothetical manner of the assembly

Technical details accepted at the construction of the plate with ball KH4-1:

D-value : 23,5 kN

maximum vertical cup load: 150 kg

From manufacturer

This unit KH4-1 is designed to assembly as following:

- corresponsive to this trucks - some producers of cars adapt the construction of the chassis of the car to installing higher described plate with ball. In such case one ought to install her local with compactly definite by the producer of the car

- complete constructions proposed by producers of tow hooks. The present unit is constructed according to requirements of regulation EKG/ONZ 55.01. Causes this that he can be prosperously practical in peaceable constructions with requirements of above mentioned regulation.

Torque settings for nuts and bolts (8,8):

M12 - 87 Nm

NOTE

After install the towbar you should get adequate note in registration book (at authorised service station). The car should be equipped with:

- Indicators
- Tow mirrors

After 1000km of exploitation check all bolts and nuts. The ball of towbar must be always kept clear and conserve with a grease.